



POLYVERA

**vintage digital
with an analog heart**



osc2
audio rec

w-table
Wave2.2
+0.00
0-SoManySe
SYNC

user manual



Suonobuono AB, Stockholm, Sweden

Polyvera manual, version 0.94, June 2026

Based on firmware release 0.36

Latest manual and firmware available at suonobuono.net/downloads

Table of Contents

How to Use This Manual	2
Essential Safety Instructions	3
Foreword.....	4
Overview	6
User Panel and First Time Use	11
Sound Management	18
Performance Control	20
Oscillators	23
Sampler	30
Analog Filter (VCF)	33
Envelopes.....	36
Low Frequency Oscillators (LFO).....	39
Modulation Matrix.....	42
Effects	46
Arpeggiator	48
Sequencer	49
Sequence Recording	50
Audio Recorder	51
User Samples	54
User Wavetables	56
MIDI Settings.....	57
System Settings.....	61
Using the External Audio Input	62
Calibrating the Filters.....	62
Appendix.....	63
Legal Terms	72

How to Use This Manual

Polyvera is a complex instrument with deep controls and some unique features. While preset sounds can provide a useful starting point, most of the fun comes from designing your own sounds.

I strongly recommend reading at least the Essential Safety Instructions, User Panel and First Time Use, and Sound Management sections before using the instrument. The remaining parts can be consulted as needed. Please check whether your questions are already answered in the manual before contacting customer service :)

This manual uses these conventions:

Bold indicates the full name of parameters and menus.

[Bold] indicates text as shown on the panel or in the menus, which is often a shortened version of the full name.

Bold italic indicates an Item in a menu page. Items can be scrolled using the **[left]** encoder.

Some parameters can either be accessed by panel, or by menu.

Menu: **[osc1]** or **[osc2]** → **[P1:TYPE]** → ***Type***

The above example text means that a parameter is accessible in the menu by selecting either the **[osc1]** or **[osc2]** menu, then by selecting the ***Type*** menu page associated to the **[P1]** button, and then by selecting the ***Type*** menu item using the **[left]** encoder. All menu parameters are adjusted using the **[right]** encoder.

Panel: **[osc1]** + turn **[wave]**

The above example text means that a parameter is modified directly from the panel by pushing the **[osc1]** button and by concurrently turning the **[wave]** knob.

Responsibility

Suonobuono AB is not liable for any erroneous information contained in this manual. The contents of this manual may be updated at any time without prior notice. We made every effort to ensure the information herein is accurate and that the manual contains no contradictory information. Suonobuono AB accepts no liability in regard to this manual other than those required by local law. Any portion of this manual may not be reproduced in any form without the manufacturer's written consent.

Essential Safety Instructions

Carefully review these safety recommendations before using your device. They highlight key precautions to ensure safe handling and operation of electronic equipment. Make sure to read all guidelines thoroughly before starting to use the device.

IMPORTANT:

1. This product, when paired with an amplifier, headphones, or speakers, has the potential to generate sound levels that can cause permanent hearing damage. **Avoid operating at high volumes or levels that cause discomfort for extended periods.** If you experience hearing loss or ringing in your ears, it is recommended that you consult an audiologist promptly.
2. Be sure to thoroughly read and understand the instructions provided in the Essential Safety Instructions section of this manual.

NOTICE:

Charges for service arising from a lack of understanding of the product's features or functions—when it is operating as intended—are not covered under the manufacturer's warranty. These costs will be the responsibility of the owner. It is advised to carefully review this manual and contact the manufacturer for guidance before requesting service.

Operating environment

- Ensure the device is only used indoors, in closed and dry areas.
- Do not operate the device in humid places like bathrooms, near swimming pools, or in washrooms.
- Keep the device away from environments with heavy dust or dirt.
- Always maintain clear ventilation around the device to prevent overheating.
- Position the device away from heat-emitting objects such as radiators.
- Avoid exposing the device to direct sunlight or strong vibrations.

Handling the Power Supply

- Always use the power supply supplied with the device.

- Disconnect the power supply if the device will remain unused for an extended duration.
- Never unplug the device by pulling on the cable; grip the plug itself.
- Refrain from handling the power plug with wet hands to prevent electrical hazards.

Safe Operation Practices

- Place the device on a sturdy, flat surface to prevent tipping or instability.
- Avoid placing any liquid-filled items on or near the device.
- Ensure foreign objects do not enter the device. If this happens, turn it off, unplug it, and seek professional assistance.
- The device may produce high sound levels that could harm your hearing. Use caution when adjusting volume and always keep it within safe limits.

Maintenance and Cleaning

- Do not open the device or attempt to repair it yourself. Repairs and servicing must be carried out by qualified professionals.
- There are no internal components that require user maintenance.
- Use a soft, dry cloth or brush for cleaning. Avoid using chemical cleaners, alcohol, or similar substances, as they may damage the finish.

Intended Use

This device is exclusively designed to generate low-frequency audio signals for sound production. Any other use is prohibited and will void the warranty provided by Suonobuono AB. Suonobuono AB is not liable for damages due to incorrect use.

Foreword

Why Did I Design Polyvera?

This is a question I asked myself many times during the design process, which ended up being way more complex than I anticipated:). In the end, I believe that it was worth it.

Polyvera revives and reshuffles some of the elements that characterized the early 80s digital sound. It is not a clone/copy, but rather an original homage to a sound

that I love, enriched with fat and modern analog filters, powerful modulations and effects. The user-friendly panel enables users to design complex sounds quite effortlessly, after a little practice.

It is the instrument that I, personally, would have liked to own and play, and which I really hope that you, as a Customer and Supporter, will enjoy as much as I do! If you have comments or feedback, don't hesitate to contact me on suonobuono.net.

Thanks, Stefano
Polyvera's Designer

A Nerdy Bit of History

Until the end of the 70s, analog technology dominated the synthesizer market with some classic instruments that are still popular today for their powerful and raw sound. During the 80s, digital technology reached the maturity level that made it possible to synthesize waveforms in the digital domain (digital filters had to wait a few more years). Among the most notable examples are the PPG® Wave 2 wavetable synths from early 80s, the Akai® S-612 sampler from 1985 and the Ensoniq® Mirage affordable sampler from 1984^[1]. The cost and limitations of digital technology forced the engineers of that time to come up with brilliant but approximate compromises, which distort the sound with artifacts that some musicians call digital "grit".

Contrarily to what is commonly read on the internet, low quantization plays, in my opinion, a quite minor^[2] role in defining that digital sound. What's more characteristic is that those instruments had pretty poor (by today's standards) anti-aliasing and anti-imaging filters, as well as primitive interpolation algorithms. This resulted in distortion both at low frequencies and at high frequencies (frequency alias producing dissonant tones). Add a few more aspects, such as the fact that frequency tracking was approximate, that A/D and D/A converters introduced coloring and that sampling frequencies were pretty low, and you get the key ingredients to that lo-fi 80s digital sound.

As the 80s passed, technology rapidly improved to the point that digital synths sounded more realistic and cleaner. Nevertheless, some of us started missing that unapologetic digital signature.

Acknowledgments

Many people contributed, directly or indirectly, to the development and launch of Polyvera. A big thanks goes to Johan and the JAM team in Stockholm, for continuous support during development and later. I also want to thank all sound designers who contributed to factory presets and the samples factory library: Alessandro Gaffuri, Alessandro Mastroianni, Alex Cummings, Henrik Johansson, Johan Antoni, Luca

Minelli, Mario Scarfiglieri, Mike Sheridan, Paulee Bow, Pete Cannon, Sebastian Galassi, Vincenzo Bellanova.

Another big acknowledgment goes to the many users who have patiently reported bugs and suggested improvements, and especially to Martin B: Polyvera is a better instrument thanks to you!

Last but not least, thank you to my family and especially to the “real” Vera, for bearing with me during stressful and hectic times.

Overview

Contents

Thanks for purchasing Polyvera! In the package you will find:

- A Polyvera synthesizer, including the SD memory card with factory content.
- A 12V 2A DC Power Supply with center-positive (5.5mm x 2.5mm plug). Please contact Suonobuono in case of doubts and before performing any potentially hazardous connection to the mains.
- A USB cable.
- Essential Safety Instructions and other locally required safety warnings.
- This instruction manual.

Connections

The back panel provides the following connections:

- Security hole: Kensington® anti-theft.
- Power connector: 12V 2A DC Power Supply socket with center-positive (5.5mm x 2.5mm plug), to be used with the provided power supply. If a replacement power supply is needed, please contact Suonobuono.
- Memory card: microSD. Polyvera cannot boot if the provided SD card is not in the slot. Never insert or extract the SD card while Polyvera is turned on, or the SD card may get corrupted.
- USB Type B, for use with a USB MIDI compatible host.
- MIDI In/Out/Through with 5-pin DIN: connection to standard-compliant MIDI devices.

- Sustain: 1/4" (6.35 mm) TS. Connection to a normally open sustain footswitch.
- Expression: 1/4" (6.35 mm) TRS, Tip = Pot center tap; Ring = 5V; Sleeve = Ground. Connection to an expression pedal.
- Audio In: 1/4" (6.35 mm) TRS (semi-balanced) connection to an external line-level audio source.
- Audio Out: 1/4" (6.35 mm) TRS (semi-balanced) connection to an external line-level mixer input or audio interface.
- Phones: 1/4" (6.35 mm) TRS (stereo unbalanced) connection to headphones. Be careful with sound level which may be loud and damage your hearing. Always start the instrument with a low volume.

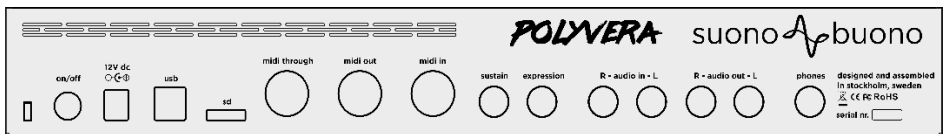

Sound Architecture

Polyvera inherits a classic hybrid subtractive polyphonic synth architecture with 2 independent digital oscillators, a multi-mode analog filter (VCF) and an analog amplifier (VCA) per voice. The voices are then mixed and fed into two serial effects (fx1, fx2).

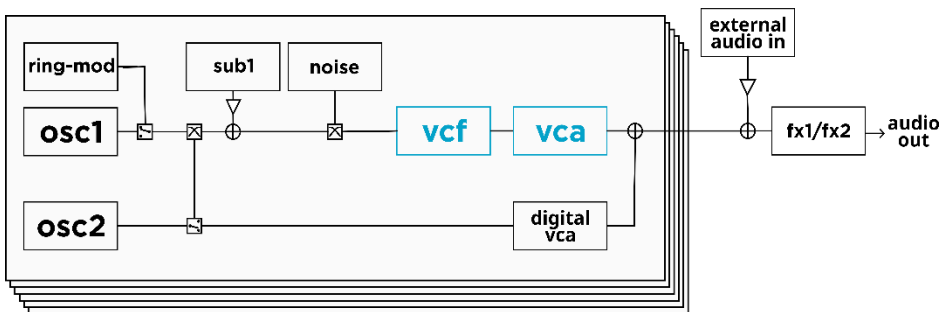

In addition to the oscillators, each voice can be enriched by a sub-oscillator (sub1), a ring-modulator, a noise generator and a waveshaper. Optionally, osc2 may be routed to a digital VCA instead of the analog VCF and VCA. This is useful to achieve different filtering and dynamics on the two oscillators.

It is possible to mix external audio to the voices and process it with the effects. The same external audio input is used for recording (sampling) external sounds.

The two effects are serial and can be mixed individually. The dry path of the effects is analog, hence only the wet part of the effects goes through A/D and D/A conversion.

Oscillators

Oscillator 1 (Osc1) is a wavetable or superwave oscillator, complemented by a flexible sub-oscillator.

Oscillator 2 (Osc2) can act as wavetable, superwave or as sampler. When the sampler is engaged, a single audio sample is spread over the entire keyboard range, giving a typical 80s lo-fi flavor that works nicely on certain sounds. Osc2 is usually routed to the VCF, together with Osc1. However, it is also possible to skip the VCF and route Osc2 directly to the VCA, which can use the same envelope (amp env) as the main VCA or the modulation envelope (mod env). This flexible routing allows for example to use a sample for the attack of the sound and a wavetable for its body.

Osc1 may be synced to Osc2, and a ring modulator between the two oscillators is also available.

Both oscillators can mimic different styles of digital artifacts (aliasing, imaging, detuning, quantization), typical of vintage digital synths and samplers from the early 80s.

In addition to the 2 oscillators there are a flexible noise generator and a ring modulator, which can be mixed to the oscillators. The ring modulator multiplies the signals of the 2 oscillators to produce harsh, inharmonic sounds. The noise generator is useful for sound effects, drums, and for spicing up many other sounds.

The drift parameter controls the emulation of pitch imperfections of analog oscillators and can be used to fatten the sound.

Filters

Polyvera's analog multi-mode filter (VCF) contributes greatly to its sound signature. It is an original, modern design based on a European-made replica of a vintage analog chip. The filter can have different profiles: low pass with 1/2/3/4 poles, 4 poles high pass, band pass, peak, and analog distortion low pass. This last configuration adds an analog distortion stage per voice, useful for "acid" sounds and many more. When the VCF resonance is fully cranked up, the filter self-oscillates and can be used as a sinusoidal oscillator.

The Drive parameter can control saturation of the input stage of the filter, which alters its tone and dampens resonance. My advice is to stick to low levels of drive to maximize the nuances of resonance, and only increase drive if a tighter, saturated sound is desired. The VCF is also provided with frequency modulation driven by Osc2 and with adjustable note tracking. Alternatively, Drive can also control a waveshaper at the input of the VCF, which acts as an extreme form of creative distortion.

The analog amplifier (VCA) shapes the volume dynamics of each voice. The level knob controls the VCA gain while the distortion LED indicates distortion of the VCA stage (which should be avoided!).

Envelopes and LFOs

There are 3 envelopes per voice. The first two are hardcoded respectively to the VCF and VCA, while the third one (mod env) can be used as a modulation source. The mod env is loopable and configurable as AD, AR, or ADSR.

There are also 3 LFOs per voice, with adjustable waveforms, frequency, fade-in time and level. Each LFO can be synced to the master tempo and its phase can be reset by key press. It is possible to optionally set the LFOs as common across the voices, as is often the case for vintage synthesizers, or as independent per voice, which produces a more complex sound. The LFO waveforms can be decimated for a stepped effect.

Modulations

Polyvera has a flexible modulation matrix with 8 slots. Each slot allows to select a source, such as an LFO, the mod env, the Mod-Wheel, etc., a destination such as the oscillator pitch or the filter frequency, and a modulation level.

Effects

There are two flexible effects in series at the end of the audio path. Both effects offer a few presets each, which are adjustable by the user. Fx1 offers chorus, phaser and delay, while fx2 offers a few reverbs. Delay time can be synced to the master tempo and the effects mix can be modulated.

Voicing

Polyvera offers classic voicing configurations (polyphonic, monophonic, legato, unison). Additionally, a binaural mode where each key triggers 2 voices, mapped respectively to the left and right channel, is offered. The binaural voicing provides great stereophonic width, at the expense of halved polyphony. There is also a chord mode, where each key triggers a user-defined chord.

Arpeggiator and sequencer

The onboard arpeggiator performs all classic patterns. Step length and notes gate length are controlled individually.

The sequencer supports up to 64-step polyphonic sequences, including one parameter automation per step. Steps can have varying gate lengths, and they can be post-processed individually.

MIDI control, MPE and pedals

Polyvera can be controlled using classic 5-pin MIDI or by USB-MIDI. When the MPE mode is selected, standard MPE MIDI commands are recognized and can be used as modulation sources. Sustain and expression pedals are also supported.

External audio and sampling

The stereo external audio input can be used for two purposes: processing external audio using Polyvera's onboard effects or recording external audio to be used in the sampler oscillator. Recorded audio is stored in .wav format on the SD memory.

Oscillator Types

Wavetable oscillator

A wavetable oscillator produces waveforms that are read from wavetables. A wavetable encompasses a collection of a few basic waveforms, called frames. Since a frame can represent an arbitrary waveform, wavetable synthesis can span a wide range of sounds. A wavetable in Polyvera is a collection of up to 64 single cycle frames. At any time, a single frame is selected and determines the timbre of the oscillator at that particular time.

Basic wavetables can for example include common analog waveforms (saw, square, triangle, etc.), while more complex wavetables can for example mimic acoustic instruments, or they can generate digitally-created complex spectra, as heard in some of the iconic wavetables of the PPG® Wave series.

The selected frame index can be modulated over time, to obtain sounds with dynamic harmonic contents. In Polyvera, this can be done in different ways: the **osc shape** parameter can be manually swept using the **[osc shape]** knob, or it can be modulated by any modulation source.

The timbre of vintage wavetable synths derives from a combination of factors, including the way their iconic wavetables were created, their resolution limitations

and the circuits and algorithms used for adjusting their pitch. All these vintage quirks are re-created in Polyvera and can be (optionally) applied to any wavetable.

Polyvera's factory library of wavetables provides a broad range, including early digital waveforms, analog waveforms sampled from eminent instruments and modern, computer-created waveforms. User wavetables in .wav format can easily be added.

Sampler

A sample player, or sampler, reproduces a pre-recorded sound sample at a certain pitch, which may be higher or lower than the original pitch of the sample. There is no perfect way of performing pitch shifting, and the first samplers used quite primitive (for today's standards) pitch shifting algorithms, which however happened to introduce characteristic sound artifacts. Polyvera's sampler reproduces those classic artifacts and applies them to any sample, according to the chosen **osc style**. Samples can be looped and loop points can be controlled by the panel (using the **[osc2 shape]** knob) and modulated, which is useful for creating interesting variations. It is also possible to assign **[osc2 shape]** and associated modulations to sample decimation, for really lo-fi effects.

Polyvera does not support multi-sampling. This is a design choice, aiming at making sampling intuitive and fun, with limited menu-diving. The goal of the Sampler is not to achieve a realistic grand piano reproduction (there are great VST plugins for that), but to blend with the intuitive and creative workflow of the rest of the synthesizer.

Superwave oscillator

In simplified terms, the superwave oscillator consists of a swarm of detuned basic oscillators within each voice. It is freely modeled after the Roland® JP-8080 Supersaw and it extends it with additional waveforms beyond sawtooth.

The **osc shape** parameter controls the level of detune. It can be manually swept using the **[osc shape]** knob, or it can be modulated by any modulation source.

User Panel and First Time Use

This section provides general guidelines for using the user panel. Each function and parameter is described in more detail in its dedicated section later in this manual.

Polyvera's panel is carefully designed to allow one-knob-per-function for the most common parameters. The remaining parameters can be accessed via the menu.

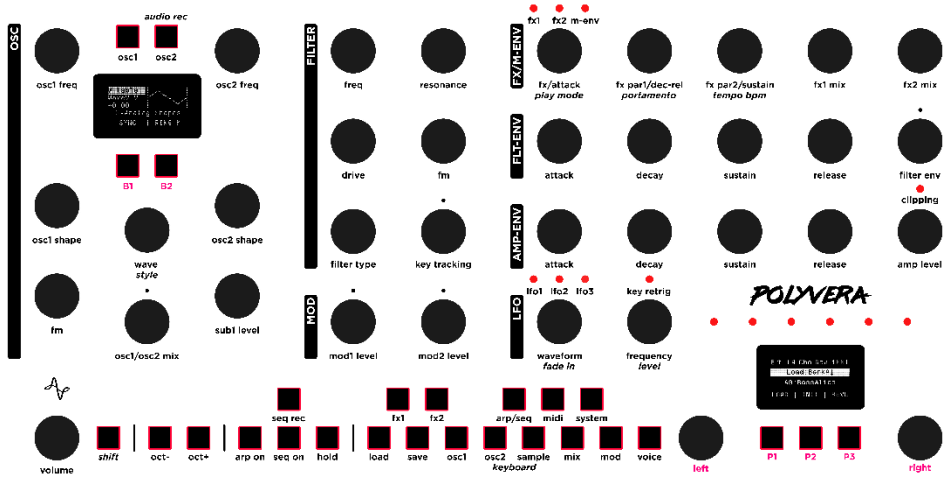

In the figure, some buttons and encoders are colored in magenta using the name that is referred to in this manual. Magenta-colored buttons and encoders are unlabeled on the actual product panel.

Shift

The **[shift]** button enables alternative parameters for some of the buttons and encoders, labeled in *italic* on the panel. To control the alternative parameter, push **[shift]** while the button/encoder of interest is adjusted.

Multi-function Encoders and Buttons

Some encoders and buttons can control multiple parameters and can be shared across oscillators, LFOs and effects.

- Oscillators section: select one of the 2 oscillators with the **[osc1]** and **[osc2]** buttons, or by pushing the nearby encoders **[osc1 freq]** and **[osc2 freq]**. The osc display, the buttons **[B1]**, **[B2]** and the **[wave]** encoder apply to the selected oscillator. The selected oscillator is indicated by the LEDs on buttons **[osc1]** and **[osc2]**.

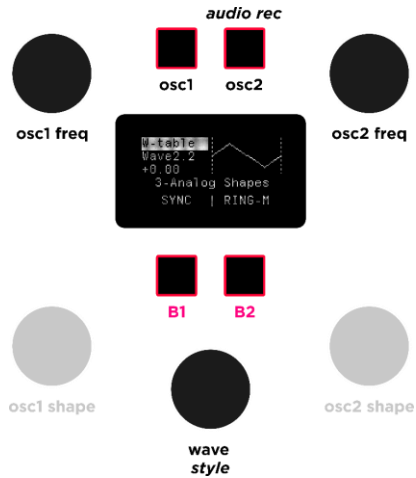

- LFO section: push the **[waveform]** encoder to select one of the 3 LFOs, which is indicated by the blue LED. The **[waveform]** and **[freq]** encoders apply to the selected LFO.

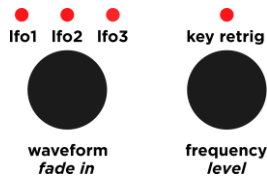

- FX section: push the **[fx/attack]** encoder to select one of the two effects or the mod-envelope, as indicated by the red LEDs above **[fx/attack]**. If one of the effects is selected, encoders **[fx/attack]**, **[fx par1/dec-rel]** and **[fx par2/sustain]** apply to the selected effect. If the mod-envelope is selected, the encoders apply to the parameters of the envelope.



Main Display and Menu Navigation

All parameters and operations that are not directly controlled by a dedicated knob are accessed using the menus. There are several menus in Polyvera, which are selected using the menu buttons.

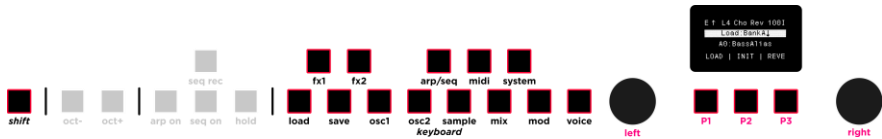

Each menu is further organized into up to 3 pages, which are accessed by the **[P1]**, **[P2]**, **[P3]** buttons.

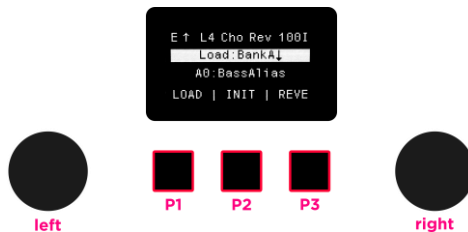

As a general rule, each page includes one or more menu items, which are scrolled using the **[left]** encoder. Most menu items indicate a parameter (e.g., **osc1 type**). Parameter values are changed by rotating the **[right]** encoder.

For most parameters, the range can be scrolled faster by pushing **[shift]** while turning the **[right]** encoder. Parameters related to sample positions in the **[sample]** menu can be adjusted with medium speed by pushing the **[right]** encoder while turning it.

There are a few exceptions to the above general rule. In some cases, the buttons **[P1]**, **[P2]** or **[P3]** may prompt an action when pressed, rather than selecting a menu page. This is the case, e.g., when pressing **[P2:INIT]** for initializing a sound.

The **rename** page and the **[mod]** menu work slightly differently than described above and their use is explained in the corresponding sections.

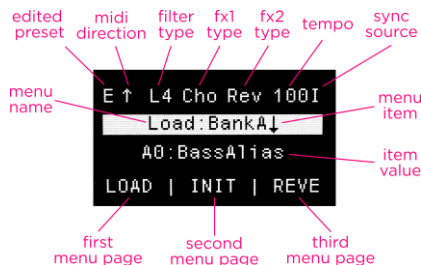

The main display shows the selected menu, the names of the menu pages accessed by **[P1]**, **[P2]** and **[P3]**, the selected menu item and its value. The display header provides other useful information:

- An indication (**E**) that the currently loaded sound preset has been changed
- Indication of incoming/outgoing MIDI traffic
- The VCF type
- The fx1 effect type
- The fx2 effect type
- The system tempo in bpm
- The tempo sync source in use. Possible values are **I**=internal clock, **L**=external MIDI sync successfully locked, **U**= external MIDI sync unlocked.

Oscillator Display

The leftmost display provides visual information about the oscillators. To select an oscillator, use the **[osc1]** and **[osc2]** buttons, or push the nearby encoders **[osc1 freq]** and **[osc2 freq]**. The selected oscillator is indicated by the backlight on buttons **[osc1]** and **[osc2]**.

For a wavetable or superwave oscillator, the display provides indication about the selected **osc style**, the oscillator detuning in semitones, the selected wavetable and a drawing of the waveform of the frame index currently selected. Note that the waveform on the display always corresponds to the latest triggered voice. The display also shows the function, if any, associated to buttons **B1** and **B2**.

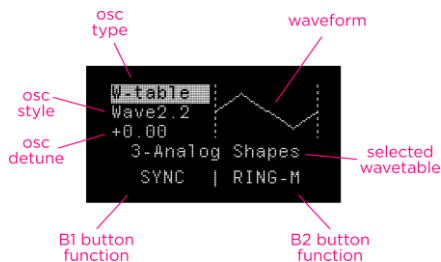

For a sampler oscillator, the display provides indication about the selected **osc style**, the oscillator detuning in semitones, the selected **sample name** and the graphical indication of indexes for sample start, sample end, loop start and loop end if a loop is active. The display also shows the function, if any, associated to buttons **B1** and **B2**.

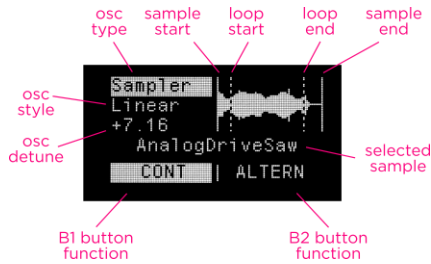

On-Panel Mini Keyboard

A button-based single octave keyboard is provided on the panel, for quick tests and whenever an external MIDI keyboard is not available. The mini keyboard is toggled by pressing **[shift] + [any of the menu buttons]**. The mini keyboard buttons are lit while the keyboard is active. To extend the keyboard range, use **[oct-]** or **[oct+]** to achieve up to +2/-2 octaves of transposition.

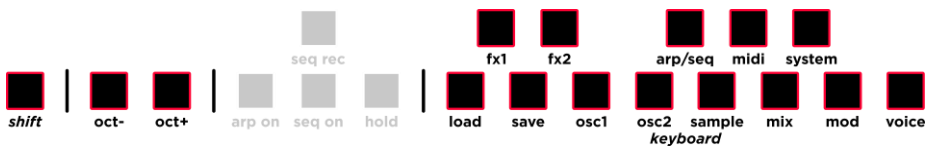

Sequencer Step Recording

When **[seq rec]** is enabled, the sequencer steps can be created and edited one by one. A special menu opens on the rightmost display, showing the current content of the selected step and buttons actions. Steps to be edited are selected using **[left]**, while **[right]** controls the note length. Notes are input using the keyboard (via MIDI or using the panel keyboard) and automation data is created by moving a corresponding knob on the panel. Buttons **[P1]** and **[P3]** provide further actions, as discussed in the dedicated section of the manual.

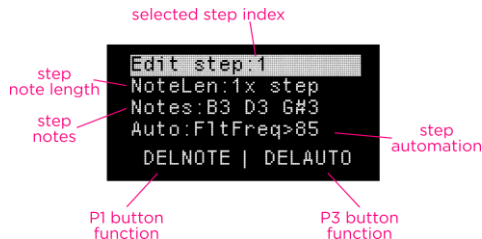

Audio Recording

Pushing **[shift]+[osc2]** starts the **audio rec** menu, which is used for sampling external audio. When **audio rec** is engaged, sound generation is disabled. To exit **audio rec**, push **[osc2]** again.



Connecting and Powering Polyvera

Polyvera uses an external power supply. Do not use any power supply or adapter other than the original one. Suonobuono accepts no responsibility for damage caused by use of an unauthorized power supply. Do not place this product in a place or position where one might walk on, trip over, or roll anything over power cords or connecting cables.

Always power-off all audio gear before making any connections. Failing to do so may damage your speakers, the synthesizer, other audio equipment or your ears. After completing all connections, set all levels to zero. Power-on the devices, with the audio amplifier or monitoring system last, then raise the volumes to a comfortable listening level.

Before powering Polyvera on/off, turn your amp's volume to zero to avoid damage due to on/off switching noise. If using headphones, avoid wearing them while powering on/off Polyvera, to avoid potential hearing damage.

Volume

The volume knob controls the level on the audio out and on the headphones out. If you are not using headphones, it is recommended to increase the output volume to the maximum and reduce the input level of the following mixer or amplifier, to achieve best noise performance over the cables.

Polyvera uses a powerful headphones amplifier which is capable of delivering sound levels that may damage hearing. Please moderate Polyvera's volume, especially if using headphones, in order to avoid hearing damage.

SD Memory Card

Polyvera stores all factory and user content (sound presets, wavetables, samples) on the external SD memory card, hence it is essential that the original card is inserted at startup. Never remove the SD memory card while Polyvera is on, it will increase the risk of corrupting the card and losing data.

It is good practice to backup user content from the SD memory card to a safe storage location. Suonobuono AB is not liable for any damage deriving from loss of data from the SD memory card.

The included memory card has been chosen among a dozen candidate models, for its speed and reliability. Do not replace it with another model, there are many counterfeit and off-specification memory cards on the market. If you need a replacement card, contact Suonobuono to order one.

The SD memory card is formatted with FAT32 and 32kB sectors. The sector size is critical and Polyvera will not work if the SD memory card is formatted differently.

To format your SD card press **[shift] + [seq rec] + [save]** while turning Polyvera on. Please note that all your user data, including presets and samples, will be lost!

Sound Management

Loading a Sound Preset

There are 8 banks {A,B,C,D,E,F,G,H} with up to 128 presets each. If no preset is found at a certain position, “No Preset” is shown on the main display.

Loading a Sound Preset

Menu: **[load] → [P1:LOAD] → Bank { A,B,C,D,E,F,G,H}**

A bank is selected with **[left]** and presets are selected and loaded using **[right]**. When loading a new sound preset, edits to the current sound are lost. To preview a sound preset without losing ongoing edits, use the **compare** function from the **save** menu.

Initializing a Sound

Menu: **[load] → push [P2:INIT]**

The sound in temporary memory is overridden by a default sound.

Reverting a Preset

Menu: **[load] → push [P3:REVE]**

The sound in temporary memory is overridden with the original content of the selected sound preset.

Saving a Sound Preset

Menu: **[save]** → **[P1:SAVE]** → **Bank** { A,B,C,D,E,F,G,H} → push **[right]**

Select the bank and the sound preset to be overridden using **[left]**, and the sound preset index to be overridden using **[right]**. Push **[right]** to execute storing of the current sound to the sound preset index shown on display. Any preset can be edited or overwritten, so be careful not to accidentally override factory presets.

Comparing a Preset

Menu: **[save]** → **[P2:COMP]** → **Bank** { A,B,C,D,E,F,G,H}

The **compare** function allows to preview a sound preset without losing unsaved edits to the current sound. Select the bank and sound preset to be previewed using respectively **[left]** and **[right]**. To return to the sound being edited, select another menu or page.

Renaming a Sound Preset

Menu: **[save]** → push **[P3:RENA]**

A simple text editor allows to change the name of a stored sound preset. **[left]** selects a character position and **[right]** changes its content. Push **[P3:OK]** to confirm the changes, or **[P1:EXIT]** to discard them.

After the preset has been renamed, a prompt allows to select the preset category.

The sound preset needs to be saved in order to store the new preset name and category.

Managing Presets on The SD Memory Card

Every sound preset is stored as a .prst file on the SD memory card. Presets can be copied, reordered and renamed when accessing the SD memory using a computer. The readme.txt file on the SD memory card provides important naming conventions that need to be followed for sound preset files, please read it carefully.

Transferring Presets Using MIDI Sysex

The most convenient way to archive, backup, rename and reorder Polyvera's presets is by reading the SD memory card with a PC. Nevertheless, Polyvera can send and receive individual presets via MIDI sysex. To do so, it is necessary to connect Polyvera to a MIDI interface that is capable of handling large sysex buffers (up to circa 10kB).

There are plenty of tools for managing sysex files on a computer, I recommend using a freeware software such as MidiOx. Currently, sysex messages are only supported over the 5-pin MIDI interface.

In order to send the current sound over MIDI sysex:

Menu: **[midi]** → **[P3:TX]** → ***Tx Current Sound?*** → push **[right]**

It is recommended to save the received sysex message as a .sys file with the name of the corresponding sound.

To load a sysex sound on Polyvera, it is necessary to first enable sysex reception:

Menu: **[midi]** → **[P2:RX]** → ***RxSoundDump*** {*yes, no*}

Once **RxSoundDump** is set to *yes*, play back a sysex file on the PC and transmit it to Polyvera's MIDI input. If the sound is correctly received, a success message will be shown and the sound in temporary memory will be overridden. If you wish to store the sound permanently, use the normal sound saving procedures and select a target preset.

Performance Control

Transposition and Keyboard Control

Octave Transpose

Panel: **[oct-]** or **[oct+]**

This parameter transposes the MIDI input by 1 or 2 octaves, upwards or downwards. Push the buttons repeatedly to increase transpose upwards or downwards.

Semitones Transpose

Menu: **[voice]** → **[P1:PERF]** → ***Transp*** {-12..+12}

This parameter controls the global transposition applied to the MIDI input.

Master Tuning

Menu: **[system]** → **[P1:SETT]** → ***Tuning*** {430.0..460.0} Hz

The **Master Tuning** parameter controls the fine tuning of the A4 note.

On-panel Mini Keyboard

Panel: **[shift]**

A button-based single octave keyboard is provided on the panel, for quick tests and whenever an external MIDI keyboard is not available. The mini keyboard is automatically enabled on the menu buttons of the panel after pressing **[shift] + [any of the menu buttons]**. To disable the keyboard, push **[shift] + [any of the menu buttons]** again. The mini keyboard buttons are lit while the keyboard is active. To extend the keyboard range, use **[oct-]** or **[oct+]**.

Hold

Panel: **[hold]**

This parameter sustains input notes as long as **hold** is enabled. To disable it, press **[hold]** again. **Hold** is very useful, for example, for drones and arpeggios.

When the **arpeggiator** is enabled, **hold** works slightly differently, by holding the latest chord until a new chord is input via MIDI.

Voice Control

Play Mode

Menu: **[voice]** → **[P1:PERF]** → *PlayMode*

Polyvera supports multiple **Play Modes**:

- *Poly*: standard polyphonic mode, voices are played at the center
- *PolyStereo*: standard polyphonic mode, voices are moderately panned to L and R in interleaved way
- *Monophonic*: single voice, envelopes are retriggered at every keypress and portamento applies to all new key presses
- *Legato*: single voice, envelopes are only retriggered when a new key is pressed and no other key is held. Portamento only applies when notes are not played staccato.
- *UnisonWide*: like Monophonic, but all voices play concurrently with slight detune and wide stereo image
- *UnisonMono*: like Monophonic, but all voices play concurrently with slight detune and centrally
- *Binaural*: like Poly, but every note triggers two voices, panned respectively L/R. Up to 3 notes may be played concurrently. This mode has a wide stereo image.
- *Chord*: a single note triggers a user-defined chord. To set a new chord, push **[right]** and then play the notes of the chord while **[right]** is still pressed. The chord will be played and transposed according to the first recorded note in the chord.

Oscillators Drift

Menu: **[voice]** → **[P1:PERF]** → *OscDrift* {*Clean, Subtle, Balanced, Extreme*}

The configurable oscillators drift emulates the behavior of analog oscillators. When set to Clean, the pitch is accurate, and no drift is applied.

Unison Detune

Menu: [voice] → [P1:PERF] → *UnisDet* {0..127}

This parameter controls the detune across the voices in UnisonWide and UnisonMono modes.

Portamento

Panel: [shift] + turn [fx par1/dec-rel] {0..127}

Portamento determines a gradual transition from one note pitch to the next one. The effect is applied independently per voice.

Controlling Tempo and Synchronization

Polyvera has an internal clock that controls the tempo of the arpeggiator, the sequencer, and any other parameters that may be synced to the tempo. If Polyvera is used together with other instruments, it can be desirable to synchronize Polyvera to those other instruments via MIDI, or to synchronize those instruments to Polyvera via MIDI.

Tempo Bpm

Panel: [shift] + turn [fx par2/sustain] {20..220}

Menu: [arp/seq] → [P3:SYNC] → *Tempo* {20..220}

This parameter determines the master tempo in beats per minute (bpm). It is only applicable when **Tempo synchronization** is set to *Internal*.

Tempo Synchronization

Menu: [arp/seq] → [P3:SYNC] → *Sync* {*Internal*, *MIDI*}

When **Tempo synchronization** is set to *Internal*, the master tempo is controlled by the internal clock. It is possible to synchronize external instruments to Polyvera via MIDI. To do so, **Midi Tx Sync** in the **Midi** menu must be *On*.

When **Tempo synchronization** is set to *External*, the master tempo is derived from incoming MIDI messages. The main display shows an approximation of the detected tempo in bpm.

The latest **Tempo synchronization** setting is loaded at startup.

External Pedals

Sustain Pedal

Notes sustain can be controlled via a normally-open sustain pedal, with TS connection.

Expression Pedal

The expression pedal can be used to control the VCA level or the VCF frequency, by setting the **Pedal Destination**. The pedal needs to use a TRS connection. If the pedal is not connected, a value 0 is read by Polyvera.

Menu: **[system]** → **[P1:SETT]** → **PedalDest** {Off, Amp, Filter}

If you are not using a pedal, set **Pedal Destination** to *Off*. The latest **Pedal Destination** setting is loaded at startup.

Oscillators

Polyvera has two oscillators per voice, with different features that are partly controlled from the panel and partly from the menus.

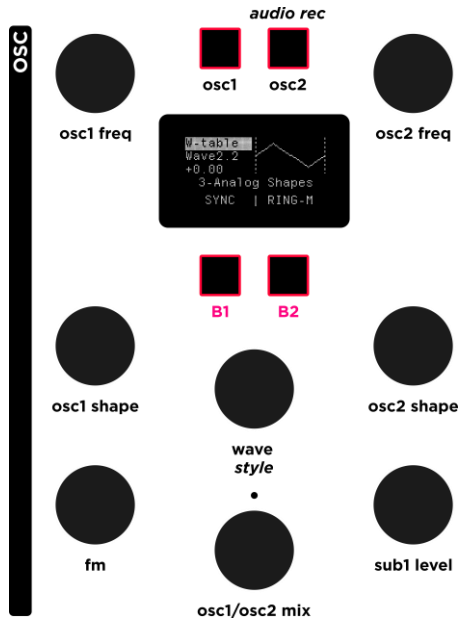

Main Oscillator Settings

Oscillator Type

Menu: [**osc1**] or [**osc2**] → [**P1:TYPE**]

Panel: [**osc1**] or [**osc2**] + turn [**wave**]

Osc1: {*Off, Wavetable, Superwave*}

Osc2: {*Off, Wavetable, Sampler, Superwave*}

Select the oscillator model among the supported ones. Sampler is only supported for Osc2, hence it is possible to load 2 wavetable oscillators in parallel, but not 2 samplers.

Wavetable/Sample Index

Menu: [**osc1**] or [**osc2**] → [**P2:WAVE**] → *Wave*

Panel: [**osc1**] or [**osc2**] → turn [**wave**]

The [**wave**] encoder selects a Wavetable or a Sample within the selected bank, depending on the selected oscillator type.

Wavetable/Sample Bank

Menu: [**osc1**] or [**osc2**] → [**P2:WAVE**] → *Bank*

Panel: [**osc1**] or [**osc2**] → push & turn [**wave**]

Wave Bank indicates the bank from which the Wavetable or Sample is selected.

Pushing the [**wave**] encoder is also a quick way to check the current bank. Check the section on Factory Content for a list of available banks.

Oscillator Style

Menu: [**osc1**] or [**osc2**] → [**P3:STYLE**] → *Style*

Panel: [**osc1**] or [**osc2**] → [**shift**] & turn [**wave**]

The **Oscillator Style** parameter determines the vintage model applied to the oscillator. The choice of models is different for Wavetable and Sampler:

Wavetable:

- *Clean*: modern interpolation with low alias, suitable for analog-like oscillator style

- *Wave 2.2*: alias and quantization based on a renowned wavetable synthesizer from the 80s, which is especially audible on low notes of waveforms with few harmonics (sine, triangle)
- *Mir1, Mir2*: alias and quantization based on an 80s sampler using zero-order interpolation and 8bit quantization. Artifacts are audible both on low notes and on high-pitched ones. Sound is bright and metallic.
- *MirMod1, MirMod2*: similar to Mir1 and Mir2, but with exaggerated alias
- *128s/8b*: the wavetable is resampled to 128 samples and quantized with 8 bits. Artifacts are quite static compared to the other models.

Note that wavetables from the *Vintage* and *User128* banks do not support multiple styles.

Sampler:

- *Linear*: relatively clean interpolation, suitable when digital artifacts are not desirable
- *Mir1*: alias and quantization based on an 80s sampler using zero-order interpolation and 8bit quantization. Artifacts are audible both on low notes and on high-pitched ones. Sound is bright and metallic.
- *Mir1-Sat*: same as Mir1, but the sampling stage is overdriven
- *Mir2-Sat*: same as Mir1-Sat, but alias is further exaggerated

Wavetable Interpolation

Menu: **[osc1]** or **[osc2]** → **[P3:STYLE]** → *FrameInterp* {off, on}

Only applicable to the wavetable oscillator.

When **Wavetable Interpolation** is enabled, the frames are smoothly blended with each other. When interpolation is off, the waveform switches from one frame to the next one without smoothing. By default, the wavetable interpolation setting is read from the wavetable file header (according to Serum®'s format) and it is updated whenever a new wavetable is selected. Automatic reading of wavetable interpolation can be disabled in the **System** menu.

***Geek's corner:** the PPG® Wave wavetable synthesizer did not support interpolation across wavetable frames, which gave an audible stepping effect when sweeping through the frames.*

Oscillator Shape

Panel: **[osc1 shape]** or **[osc2 shape]** {0..127}

The **Oscillator Shape** parameter is a flexible parameter that controls the timbre of the sound. **Oscillator Shape** can be modulated and controls different properties of the sound, depending on **Oscillator Type**:

- **Wavetable Oscillator Type**: the oscillator shape parameter controls the wavetable frame index. Modulating shape effectively modulates the frame index.
- **Sampler Oscillator Type**: the oscillator shape parameter controls a configurable parameter of the sampler, see the Sampler section for a list of options. Modulating shape effectively modulates the associated parameter.
- **Superwave Oscillator Type**: the oscillator shape parameter controls detune/fatness.

Oscillator Frequency

Panel:

- Coarse tuning (semitones): turn [**osc1 freq**], or turn [**osc2 freq**] $\{-24..+24\}$
- Fine tuning (cents): [**shift**] + turn [**osc1 freq**] or [**shift**] + turn [**osc2 freq**] $\{-0.50..+0.50\}$

These parameters detune the oscillators. The encoders normally control coarse detuning. For fine detuning, push [**shift**] while turning the knobs.

Osc1 Frequency Modulation (FM) Level

Panel: Osc section [**fm**] $\{0..127\}$

The phase of Osc1 can be modulated (so called through-zero linear FM) by the signal of Osc2. **Osc1 Frequency Modulation (FM) Level** controls the amount of modulation applied to Osc1 over a wide modulation intensity range.

Sound design tip: *FM is a powerful but complex tool. To get started with classic 80s FM sounds, configure both oscillators to sine wave, detune them by some semitones and adjust the Osc1 FM Level. Since Osc1 is modulated by Osc2, Osc1/Osc2 Mix should be fully on Osc1 for isolating the sound of FM. For decaying sounds like bass, bells, mallets, Modulate Osc1 FM Level using the Modulation Envelope. Slightly modulating Osc1 Frequency or Osc2 Frequency using LFOs gives additional timbre movement. Using other waveforms than sine adds complexity and unpredictability to the result. For unusual results, try modulating Osc1 using a sample, rather than a periodic waveform. Polyvera allows also to frequency modulate the analog filter frequency using Osc2, which sounds very differently compared to frequency modulating Osc1.*

Geek's corner: Periodic waveforms, as produced by analog oscillators, produce harmonic frequencies at multiples of the fundamental frequency, sounding harmonically pleasant to our ears. FM allows to add inharmonic, dissonant, content to an oscillator. Dissonance is required to emulate sounds such as bells, brass, mallets, etc. Frequency Modulation means that a source called modulator (Osc2 in Polyvera) modulates the pitch of an oscillator called carrier (Osc1 in Polyvera).

Osc1 Sync

Panel: [osc1] → [B1:SYNC] {Off, On}

This option enables hard sync of Osc1 phase based on Osc2. Hard sync means that the phase of Osc1 is reset whenever Osc2 starts a new wave period. It is only available when **Osc1 Type** is *Wavetable*, and **Osc2 Type** is *Wavetable* or *Superwave*.

Sound design tip: Sync is a classic trick from the analog era, where Osc2 determines the tuning of the sound but the actual audible wave comes from a modulated and synced Osc1. To achieve this in Polyvera, set both oscillators to clean sawtooth waves, sync Osc1 to Osc2, modulate Osc1's pitch upwards over several octaves using the Mod Env, using an AD envelope with zero attack and medium decay. Set the Osc1/Osc2 Mix fully to Osc1 and add the suboscillator as needed. Adjust detuning Osc1, the Mod Env decay time and Osc1's pitch modulation level to taste.

Ring Modulator

Panel: [osc1] → [B2:RING-M] {off, on}

Menu: [Mix] → [P1:RM] → *RingMod* {Off, Half, Full}

The Ring Modulator multiplies the signals from Osc1 and Osc2 and replaces Osc1 in the signal mixer. When **Ring Modulator** is set to *half*, part of Osc1 bleeds through the modulated signal. **Osc1/Osc2 Mix** tunes the balance between the Ring Modulator and Osc2.

Geek's corner: When waveforms are multiplied with each other, new inharmonic frequencies are produced, with a metallic flavor. Ring Modulation has been widely used to create sound effects and as an alternative to frequency modulation.

Sound design tip: To learn how ring modulation behaves, start by setting simple waveforms on Osc1 and Osc2 (e.g., sine, triangle,...) and progressively detune Osc1 by several semitones. Blend in the Ring Modulation and Osc2 to achieve inharmonic sounds.

Sub-Osc1 Wave

Menu: [osc1] → [P1:Type] → *SubWave* {Same as Osc1, Square, Saw, Pulse, Tri, Sine}

SubWave selects the waveform used by the suboscillator, which can be the same as the one used by Osc1, or one of a few basic analog waveforms. Note that Sub-Osc1 follows the same **Osc Style** as Osc1.

Sub-Osc1 Transpose

Menu: [osc1] → [P1:Type] → **SubTranspose** {-12, -19, -24}

SubTranspose sets the detune of the suboscillator relative to Osc1, in semitones.

Mixing Oscillators

Osc1/Osc2 Mix

Panel: [osc1/osc2 mix] {-63..+63}

Osc1/Osc2 Mix controls the levels balance of the oscillators. Note that when **Ring Modulator** is enabled, the signal from Osc1 is replaced by the ring modulator signal. In such case, **Osc1/Osc2 Mix** controls the mix between the Ring Modulator and Osc2.

Sub-Osc1 Level

Panel: [sub1level] {0..127}

Sub-Osc1 Level controls the level of the Osc1 sub-oscillator, which plays the same waveform as Osc1, one octave lower. In the signal chain, the sub-oscillator is added after Osc1/Osc2 are mixed.

Noise Mix

Menu: [mix] → [P2:NOISE] → **NoiseMix** {0..127}

Noise Mix controls the balance between the oscillators and the noise generator. When **Noise Mix**=127, only noise is audible.

Osc2 Routing

Menu: [osc2] → [P1:TYPE] → **Routing** {VCF, VCA (A-Env), VCA (M-Env)}

This parameter controls the filtering routing and VCA envelope for Osc2. The possible values are:

- **VCF**: Osc2 is routed through the same analog VCF and VCA as Osc1
- **VCA (A-Env)**: Osc2 is routed directly to the same VCA as Osc1 and no analog VCF is applied.
- **VCA (M-Env)**: Osc2 is routed directly to a VCA whose envelope is controlled by the Mod-Envelope. No analog VCF is applied.

Routing	Osc2 Filter	VCA	VCA envelope
VCF	Analog VCF	Analog	AMP-Env
VCA (A-Env)	-	Digital	AMP-Env
VCA (M-Env)	-	Digital	MOD-Env

Sound design tip: Flexible Osc2 routing can be useful when Osc2 plays a sample with a strong attack, which should typically not be filtered, while Osc1 plays a wavetable with a smoother filter envelope.

Another example application is when Osc2 plays an already filtered sample, which should not be filtered more.

Advanced Oscillator Settings

Osc2 Pitch Tracking

Menu: [osc2] → [P1:TYPE] → *PitchTrk* {Off, On}

When **Osc2 Pitch Tracking** is on, Osc2's pitch follows the input MIDI notes, similarly as Osc1. When **Osc2 Pitch Tracking** is off, a fixed note is generated by Osc2, independently of the input MIDI notes pitch. This can be useful for generating dissonant sounds, where Osc2 can be used as a high frequency modulator acting on Osc1's pitch, Osc1 sync, or on the VCF frequency.

Osc2 Fixed Pitch

Menu: [osc2] → [P1:TYPE] → *FixedPitch* {A0..C8}

Osc2 Fixed Pitch is only relevant when Osc2 Pitch Tracking is off, and it determines the fixed pitch note played by Osc2.

Noise Color

Menu: [mix] → [P2:NOISE] → *NoiseColor* {0..127}

Noise Color controls the frequency content of the noise generator. A value of 64 provides white noise, higher values give a high-pass filtered noise, while lower values give low-pass filtered noise.

Waveshaper

Menu: [mix] → [P3:DRIV] → *DriveType* {AnalogDrive, Dig Waveshaper1, Dig Waveshaper2}

The **Waveshaper** applies smooth to extreme signal distortion before the VCF, by combining analog and digital elements. Polyvera offers 3 different waveshapers:

- *AnalogDrive*: analog circuit with soft saturation
- *Dig Waveshaper1*: hybrid analog/digital wavefolder, rich in harmonic and frequency alias.
- *Dig Waveshaper2*: hybrid analog/digital wavefolder, rich in harmonic and frequency alias, freely inspired by the iconic Buchla© 259 wavefolder.

Filter Drive on the panel controls the amount of waveshaping.

Sampler

Polyvera implements a simple sample player, inspired by the first samplers in the early 80s, but without the same memory and user interface limitations. Polyvera uses one sample at the time, which is spread over the keyboard. The sample can be played forward or backwards, and it can be looped in different ways. The loop points may be controlled from the panel and modulated. The sampler quality may be altered to reproduce the artifacts (frequency alias, quantization and DAC noise, ADC saturation) of vintage samplers.

The sampler is activated by selecting **Osc Type=Sampler** on Osc2. The next step consists of selecting the desired sample. Several parameters can then be adjusted, related to the sampler vintage style, pitch, start/end indexes, loop type and loop points, etc.

Playing Samples

Sample Root Key

Menu: [sample] → [P1:PLAY] → *RootKey* {A0..C8}

The **Sample Root Key** corresponds to the key of the original sample. When a note higher than **Sample Root Key** is played, the sample is pitched upwards and accelerated. When a note lower than **Sample Root Key** is played, the sample is pitched downwards and slowed down.

Sample Root Key is automatically read from the .wav file header and it defaults to C4 if such data is not provided in the file.

Sample Direction

Menu: [sample] → [P1:PLAY] → *Direction* {Forward, Backward}

Samples can be read in either direction. When reading backward, **Sample End Index** is the first read sample index and **Sample Start Index** is the last read sample index.

Sample Start Index

Menu: [sample] → [P1:PLAY] → *StartIdx* {0..*Sample Length*}

Sample Start Index controls the first sample index read in the sample file. It cannot exceed **Sample End Index**. **Sample Start Index** is usually used to remove the empty trailing part of a sample.

To browse through the file very coarsely, press [shift] while turning [right].

To browse through the file with medium precision, press [right] while turning [right].

Sample End Index

Menu: [sample] → [P1:PLAY] → *EndIdx* {0..*Sample Length*}

Sample End Index controls the last sample index read in the sample file. It cannot be smaller than **Sample Start Index**.

To browse through the file very coarsely, press [shift] while turning [right].

To browse through the file with medium precision, press [right] while turning [right].

Loop Operations

Sample Loop Type

Menu: [sample] → [P2:LOOP] → *LoopType* {*Off*, *Continuous*, *Alternating*}

Panel:

- [B1/CONT] for enabling/disabling a *Continuous* loop
- [B2/ALTERN] for enabling/disabling an *Alternated* loop

The sample loop, when enabled, repeats the portion of the sample file between **Sample Start Loop** and **Sample End Loop**. Multiple **Sample Loop Types** are supported:

- *Off*: sample loop is disabled
- *Continuous*: continuously repeat the portion of the sample between **Sample Start Loop** and **Sample End Loop**. When the end of the loop is reached, the loop restarts from its first sample
- *Alternating*: continuously repeat the portion of the sample between **Sample Start Loop** and **Sample End Loop**, in back-and-forth fashion. When the end of the loop is reached, the loop bounces backwards, and so on.

The value of **Sample Loop Type** is automatically read from the .wav file header and it defaults to *Off* if such data is not provided in the file. To disable automatically reading **Sample Loop Type** from the sample file, disable **Read Sample Meta** in the **System** menu.

Sample Start Loop

Menu: **[sample]** → **[P2:LOOP]** → **LoopStart** {0..Sample Length}

Sample Start Loop controls the first sample index for the loop. It cannot be smaller than **Sample Start Index**.

Sample Start Loop is automatically read from the .wav file header and it defaults to 0 if such data is not provided in the file.

To browse through the file very coarsely, press **[shift]** while turning **[right]**.
To browse through the file with medium precision, press **[right]** while turning **[right]**.

If the **Sample Start Loop** does not behave as expected, check if **Sample Shape Control** is controlling Loop Length.

Sample End Loop

Menu: **[sample]** → **[P2:LOOP]** → **LoopEnd** {0..Sample Length}

Sample End Loop controls the last sample index for the loop. It cannot be larger than **Sample End Index**.

Sample End Loop is automatically read from the .wav file header and it defaults to the last index of the sample if such data is not provided in the file.

To browse through the file very coarsely, press **[shift]** while turning **[right]**.
To browse through the file with medium precision, press **[right]** while turning **[right]**.

If the **Sample End Loop** does not behave as expected, check if **Sample Shape Control** is controlling Loop Length.

Sample Shape Control

Menu: **[sample]** → **[P1:PLAY]** → **ShapeCtrl** {Off, LoopLength, SampleDecimation}

Sample Shape Control controls the sound property controlled by **Osc2 Shape**:

- *Off*: **Osc2 Shape** has no effect on **Osc2**
- *LoopLength*: **Osc2 Shape** controls the actual length of the loop, between a small value and up to the difference between **Sample Start Loop** and **Sample End Loop**

- *SampleDecimation*: **Osc2 Shape** controls sample rate decimation.

Sample Loop X-Fade

Menu: [sample] → [P2:LOOP] → *X-Fade* {Off, Short, Medium, Long}

Sample Loop X-Fade allows smoothing loops and avoiding clicks by smoothly cross-fading samples close to the edges of the loop.

Sound design tip: As a rule of thumb, shorter loops should use shorter **Sample Loop X-Fade**, however always try to find good loop points with disabled **Sample Loop X-Fade** first, before enabling it, and judge by ear. X-Fade works best when the edges of the loop are at least a few hundreds of samples from the extremes of the sample file.

Analog Filter (VCF)

Polyvera implements one analog filter per voice, with 8 filter types to choose from. The filter is based on a classic chip design from 1980, however the actual filter circuit is original and not copied from any specific instrument. Note that the resonance of the filter is more pronounced for low **Filter Drive** levels and the filter input is nicely overdriven for high **Filter Drive** levels. The filter self-oscillates at maximum resonance and can be used as a sinusoidal oscillator, as explained in the Geek's corner.

The analog filters need to be calibrated in order to ensure consistent response among them. Please check the Filter Calibration section for more info.

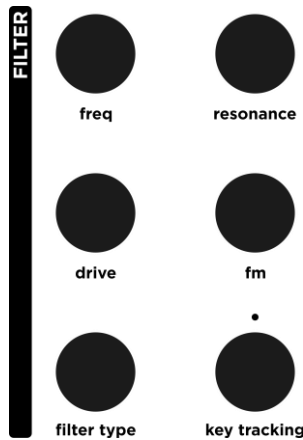

Filter Frequency

Panel: Filter section [freq] {0..127}

Base frequency of the filter, from ca 20Hz to ca 22kHz.

Sound design tip: Polyvera's analog filters are tuned and calibrated so that they can track some octaves with good accuracy. This allows to play the filters as if they were sine oscillators. To do so, crank Resonance to 127 and turn both Oscillators off, so that no signal enters the filter. Set Filter Tracking to 127 and adjust Filter Frequency appropriately.

It can also be interesting to set Filter Type to BandPass, increase NoiseMix, and adjust Filter Drive to obtain a tuned noise effect. Note that filter resonance is loud and that the Amp Level needs to be reduced accordingly to avoid unpleasant distortion.

Filter Resonance

Panel: Filter section **[resonance]** {0..127}

Resonance level of the filter. The filter self-oscillates at maximum Filter Resonance, producing a clean sine wave.

Filter Drive

Panel: **[drive]** {0..127}

Filter Drive controls signal waveshaping before the analog filter. The type of waveshaper is selected by the **Waveshaper** parameter in the menu (see the Advanced Oscillator Settings section), while **Filter Drive** controls the intensity of waveshaping.

When the **Waveshaper** is set to *AnalogDrive*, **Filter Drive** values in the range 0..64 determine a light saturation of the filter input, while higher values result in analog clipping of the waveform. The drive level is automatically compensated for in the VCA, so that increasing the **Filter Drive** does not result in major volume changes.

Sound design tip: Because of the analog nature of the filter, the drive level affects the resonance profile. Resonance is more pronounced when Filter Drive = 0, and it is dampened for higher drive values. Hence, high **Filter Drive** values are only recommended for sounds that do not require high resonance.

Filter Frequency Modulation (FM)

Panel: Filter section **[fm]** {0..127}

Filter FM controls the amount of filter frequency modulation from Osc2. Note that Osc2 needs to be active for this control to be effective, however the amount of filter modulation is independent of whether Osc2 is mixed to the audio signal.

Sound design tip: Filter FM gives very different results than Osc FM. The effect of Filter FM is more pronounced for higher resonance levels. Detuning Oscillators so that their waveforms align every few periods (e.g., by detuning them by +7, +12, -5, -12, etc. semitones) plus some cents creates periodic modulations. Try out different Osc2 waveforms for different flavors. For creative results, select a sequence sample on Osc2 to filter-modulate a classic waveform on Osc1. For sound effects and detuned drones, it can be a good idea to set fixed pitch tracking on Osc2 (see Osc2 Pitch Tracking) and create different harmonic dissonances across the keyboard range.

Filter Type

Panel: turn [filter type]

Polyvera offers 8 different analog filter types:

- Low Pass 4 poles: 24dB/oct
- Low Pass 3 poles: 18dB/oct
- Low Pass 2 poles: 12dB/oct
- Low Pass 1 pole: 6dB/oct
- Peak
- Band Pass
- High Pass
- Low Pass 3 poles: 18dB/oct + analog distortion

The last Filter Type includes a post-filter analog distortion stage per voice. Play with Filter Drive and Filter Resonance to experiment with all flavors of distortion that can be achieved.

Geek's corner: Distortion creates new harmonics from the input sound. For polyphonic sounds, per-voice distortion creates different and possibly less dissonant harmonics, compared to the same distortion effect applied to the combined polyphonic signal. Experiment with these two ways of distorting, to find the one that suits your sound best.

Filter Tracking

Panel: [tracking] {-63..+63}

Filter Tracking controls the relation between the filter frequency and the corresponding voice note index. When Filter Tracking = 0, the filter frequency is not affected by the voice note index. If a low pass filter is used, higher notes will sound darker than lower notes, which is useful for emphasizing details in the bass range. For positive Filter Tracking values, the filter frequency increases with the note pitch and the timbre becomes more homogeneous over the full keyboard range. Negative

Filter Tracking values produce the opposite effect, but they are seldom used. Filter Tracking=127 corresponds to what is often termed “full tracking”.

Envelopes

Envelope generators are fundamental functions in a synthesizer: they generate a time-varying signal which typically raises to a peak after a key is pressed, decays to a constant value, and finally fades to zero. The main parameters of an ADSR envelope correspond to the attack time, the decay time, the sustain level and the release time. Simpler envelopes may be of AD or AR type and they lack some of the stages of the ADSR envelope. An envelope is used to control parameters that should vary over time, such as the volume of a sound.

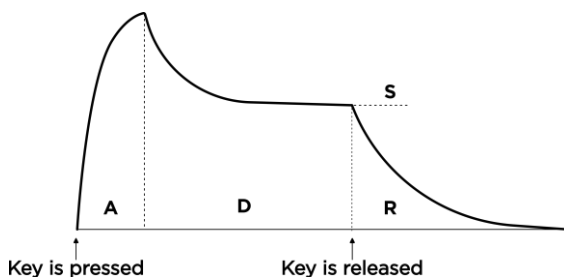

Polyvera provides three independent envelopes per voice. The first two ADSR envelopes control the voice filter and the voice amplifier, while the third one (Mod Env) is a flexible modulation source that can control assignable parameters.

Filter Envelope ADSR

The filter envelope has an ADSR profile controlled by the **[attack]**, **[decay]**, **[sustain]** and **[release]** parameters in the FLT-ENV section of the panel. Each of the values has range $\{0..127\}$.



Filter Envelope Amount

Panel: **[filter env]** $\{-63..+63\}$

The **Filter Envelope Amount** parameter scales the amount of envelope that is summed to the filter frequency. Positive **Filter Envelope Amount** values are very

common and determine a controlled opening of the filter as a new key is pressed. Negative **Filter Envelope Amount** values sound less natural but can be leveraged for interesting effects.

Amp Envelope ADSR

The amp envelope has an ADSR profile controlled by the **[attack]**, **[decay]**, **[sustain]** and **[release]** parameters in the AMP-ENV section of the panel.

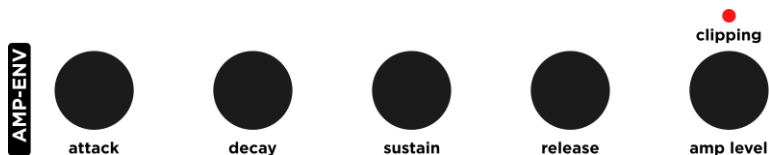

Amp Level

Panel: **[amp level]** {0..127}

The **Amp Level** parameter controls the gain of each VCA. It is important to adjust this parameter correctly to get the best performance out of every sound. The Clipping LED above the **[amp level]** knob indicates whether digital clipping is experienced by the effects stage that follows the VCA. Digital clipping simply sounds bad and should be avoided by moderating **Amp Level**. On the other hand, higher **Amp Level** values deliver improved dynamics. It is important to set a relatively high **Amp Level** value, which however does not produce any digital clipping.

Sound design tip: When creating a new sound, set **[amp level]** midway, as a starting point. When the sound is almost final, try a rich chord with the loudest setting of the sound and adjust **[amp level]** to be just below clipping level.

Geek's corner: Gain staging refers to adjusting the gain of each stage in a sound processing chain. Gain staging is not particularly critical in modern digital signal processing with 32 or 64 bit internal precision, but it is critical for analog circuits and for A/D and D/A converters. Intrinsic limitations of analog circuits determine an unavoidable noise floor power and a maximum power for undistorted signals carried by the circuit. The ratio between the maximum signal power and the noise floor determines the dynamic range of the circuit, which affects how “punchy” and “dynamic” an analog instrument is perceived. A polyphonic synthesizer with diverse sound sources and voices such as Polyvera is particularly challenging, from a gain staging perspective, because different sounds have largely different maximum signal power (depending on the number of used oscillators, on the filter type, on polyphony, etc.). By letting the user adjust the Amp Level, it is possible to optimize gain staging for each sound, but care should be paid to avoid digital clipping.

Mod Envelope ADSR

Panel: Push **[fx/attack]** until *m-env* is selected → Turn **[fx/attack]**, **[fx par1/dec-rel]**, or **[fx par2/sustain]**

The Mod Envelope is a flexible envelope that can be used to modulate any valid modulation destination, such as the pitch of an oscillator or the mix of an effect.

Note that sustain is only relevant for *ADSR Mod Envelope Type*, decay is only relevant for *ADSR* and *AD Mod Envelope Types* and release is only relevant for *ADSR* and *AR Mod Envelope Types*.

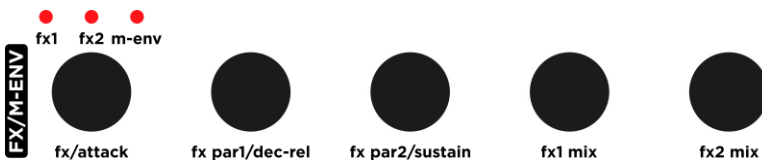

Mod Envelope Type

Menu: **[voice]** → **[P3:Env]** → **ModEnvType** {*ADSR, AR, AD, CyclicAD*}

The Mod Envelope supports multiple profiles:

- *ADSR*: classic ADSR profile, similar to the other envelopes on Polyvera. Note that the D and R time constants are the same.
- *AR*: the envelope smoothly grows to its maximum while the key is pressed, and smoothly decays to 0 after the key is released
- *AD*: the envelope smoothly grows to its maximum and then smoothly decays to 0
- *AD cyclic*: same as AD, but the envelope repeats automatically as long as the note is triggered. This mode allows to use the Mod Envelope as an additional flexible LFO.

The Mod Envelope is a modulation source and, like any other modulation source, it needs to be mapped to a modulation destination in the Modulation Matrix in order to be effective.

Mod Envelope Level

Menu: **[voice]** → **[P3:Env]** → **ModEnvLvl** {-63..+63}

This is an advanced parameter, which is only useful when you want to modulate the Mod Envelope intensity. In all other cases, leave it to its default value +63.

The **Mod Envelope Level** defines the intensity of the envelope. It works in a similar way as the **Filter Envelope Amount**. If **Mod Envelope Level** is set as a modulation destination, the parameter **Mod Envelope Level** defines the base value on top of which modulation is added.

Low Frequency Oscillators (LFO)

LFOs are another essential function in a synthesizer. They are oscillators that operate at frequencies ranging from small fractions of Hz to at most hundreds of Hz. Differently from the main Oscillators, LFOs frequency is independent of the pressed key and their signal is not directly added to the sound path, but it is instead used as a modulation source to modify other sound parameters over time.

There are 3 functionally identical Low Frequency Oscillators (LFOs) per voice in Polyvera, whose frequency range goes from one cycle over one minute, up to lower audio rate. Their frequency may be synced to the master tempo and their phase may be retriggered by key press. The intensity and frequency of LFOs can be modulated (see the Modulation Matrix section, including Sound design tips) and a fade in parameter allows to gradually increase the LFO intensity when a new key is pressed.

Classic analog synths usually shared the same LFO across all voices, which is also

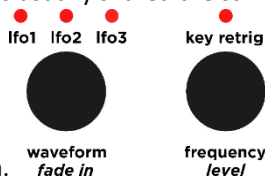

allowed by Polyvera.

LFO Waveform

Panel: Push **[waveform]** until the desired LFO LED is blue, then turn **[waveform]**

The following LFO waveforms are supported: *Tri*, *Saw*, *Square*, *Sine*, *S&H*, *Random Binary*, *Random Ternary*, *Filtered Noise*, *Chirp*, *Antisymmetric Chirp*, *RingMod*, *Saw Mix*, *Soft Saw*, *Rez Saw*, *Soft Square*, *Rez Square*, *Sat Sine*, *Osc1 Wave*, *Osc2 Wave*.

The last two waveforms are special: they reuse the same modulated wave currently used by one of the oscillators, provided that the oscillator is of Wavetable Type. In this way, you have access to unlimited LFO waveforms, as long as they are loaded as wavetable on one of the oscillators. It is also possible to modulate the LFO waveform by modulating the Oscillator wave.

LFO Frequency

Panel: Push **[waveform]** until the desired LFO LED is blue, then turn **[frequency]** $\{0..127\}$

The actual frequency is scaled logarithmically for better control, from one cycle per minute to over 100Hz. For noise-like LFO waveforms, **LFO frequency** controls their bandwidth.

If an LFO is synced to master tempo, **LFO frequency** is expressed with respect to the master tempo.

LFO Synchronization

Menu:

- **[voice]** → **[P2:LFO]** → **Lfo1Sync** $\{Off,On\}$
- **[voice]** → **[P2:LFO]** → **Lfo2Sync** $\{Off,On\}$
- **[voice]** → **[P2:LFO]** → **Lfo3Sync** $\{Off,On\}$

Sometimes, it is useful to synchronize the LFO frequency to the master tempo, so that LFO periods follow the music patterns in a rhythmically interesting way. For example, during an arpeggio, one may want to perform exactly one LFO cycle per step, without having to adjust LFO frequencies whenever the arpeggio tempo is changed. **LFO synchronization** is enabled individually per LFO from the menu. When **LFO synchronization** is enabled, **LFO frequency** is expressed as a fraction of a bar (i.e., 4 beats).

LFO Key Retrigger

Panel: Push **[waveform]** until the desired LFO led is blue, then push **[frequency]** to toggle **LFO key retrigger** $\{Off, On\}$

Sometimes it is desirable to restart the phase of an LFO whenever a new key is triggered. This behavior provides a more consistent timbre for every played note. **LFO Key Retrigger** is enabled per LFO from the panel.

LFO Level

Panel: Push **[waveform]** until the desired LFO led is blue, then push **[shift]** while turning **[frequency]** $\{-63..+63\}$

LFO Level controls the signal level for each LFO. Negative values result in phase inversion.

LFO Level can often be left at +63, except for the case where the LFO level needs to be modulated. In such case, use **LFO Level** to set the base value on top of which modulation is added. The blinking intensity of the LFO LEDs reflects the LFO signal.

***Sound design tip:** When a bipolar modulation is applied to **LFO Level** and the base LFO level is 0, phase and level modulations can be achieved concurrently, which is unusual and cool. Set modulation slot1 to modulate **Filter Freq** using a sawtooth waveform on LFO1, with **Mod1 Level** +63. Set **LFO1 Level** to 0: the filter frequency should be unaffected by the LFO. Now, set modulation slot2 to modulate LFO1 level, for example using LFO2 as modulation source and a ternary LFO2 waveform. Set **Mod2 Level** +63. The filter frequency is now randomly modulated in 3 ways: upwards sawtooth, downward sawtooth, or no modulation.*

LFO Fade In

Panel: Push **[waveform]** until the desired LFO led is blue, then push **[shift]** while turning **[waveform]** {0..127}

This parameter controls the fade-in time constant for each LFO. Whenever a new key is pressed, the LFO level gradually increases from 0 until the value determined by **LFO level** is reached. When **LFO fade in** is 0, the LFO level is unaffected by new keys being pressed.

LFO Common Mode

Menu:

- **[voice]** → **[P2:LFO]** → **Lfo1Common** {Off, On}
- **[voice]** → **[P2:LFO]** → **Lfo2Common** {Off, On}
- **[voice]** → **[P2:LFO]** → **Lfo3Common** {Off, On}

Having independent LFOs per voice allows for complex modulations and lots of movement, but that can also be overwhelming at times. Polyvera offers the possibility to share the same LFO across all voices, which can sometimes be beneficial. When **LFO Common Mode** is enabled, all voices experience the same LFO phase and frequency. Furthermore, when **LFO Common Mode** is enabled, the LFO phase and LFO fade in for all voices are re-triggered whenever a new key is pressed.

LFO Sample & Hold

Menu:

- **[voice]** → **[P2:LFO]** → **Lfo1 S&H** {Off, 64, 32, 16, 8, 4, 2}
- **[voice]** → **[P2:LFO]** → **Lfo2 S&H** {Off, 64, 32, 16, 8, 4, 2}
- **[voice]** → **[P2:LFO]** → **Lfo3 S&H** {Off, 64, 32, 16, 8, 4, 2}

LFO Sample & Hold controls decimation of LFO waves, to achieve a stepped result. The parameter indicates the number of steps used to represent a single LFO waveform period.

Modulation Matrix

Polyvera offers a user-configurable modulation matrix with 8 freely assignable slots. Every slot includes a modulation source, such as an LFO, a destination parameter, such as the filter frequency, and a modulation level. Every parameter has a base level, which corresponds to the parameter value before any modulation is applied. Modulations can increase or decrease the value of the parameter, relative to its base value.

Note that one modulation source can be used to modulate multiple parameters, using different slots. A destination parameter can also be modulated using multiple modulations sources and modulation slots.

Modulations are accessible by menu, however the panel provides a convenient shortcut for setting modulation destinations and levels by using knobs.

Modulation Sources

Modulation sources are either unipolar or bipolar. Bipolar sources can both increase and decrease the destination parameter, compared to its base value. Unipolar modulation sources can either increase or decrease the destination parameter. Unipolar sources are identified by a “+” in their name, remaining sources are either bipolar or configurable.

Menu: **[mod]** → turn **[left]** until the desired modulation slot is shown on the menu display. Then push **[P1:SRC]** → turn **[right]**

Modulation sources	Polarity	Granularity	Comments
<i>LFO1, LFO2, LFO3</i>	Bipolar or Unipolar	Voice or common	LFO signal
<i>ModEnv+</i>	Unipolar	Voice	Mod Envelope signal
<i>FltEnv+</i>	Unipolar	Voice	Filter Envelope signal
<i>Velocity</i>	Bipolar or Unipolar	Voice	Midi note velocity. When Bipolar is selected, velocity values above 64

			deliver positive modulation, values below 64 deliver negative modulation. When Unipolar is selected, velocity always delivers positive modulation.
<i>NoteNr</i>	Bipolar	Voice	Midi note number. Values above 64 (E4) deliver positive modulation, values below 64 deliver negative modulation
<i>ModWheel</i>	Configurable	Common	Standard MIDI modwheel, mapped to CC1. Polarity can be configured in the midi menu
<i>Aftertouch+</i>	Unipolar	Voice and common	Combination of MIDI channel aftertouch and MIDI polyphonic aftertouch
<i>MpeSlide</i>	Configurable	Voice (for MPE MIDI Mode) and common (for all MIDI Modes)	CC74, often referred to as “Slide” according to the MPE standard. Polarity can be configured in the midi menu
<i>MidiModulator1, MidiModulator2, MidiModulator3, MidiModulator4</i>	Configurable	Common	General purpose modulators CC9, CC114, CC115, CC89. Polarity can be configured in the midi menu
<i>Random</i>	Bipolar	Voice	Random value, updated by every key press

Modulation Destinations

Modulation destinations include all the parameters commonly included in classic analog synthesizers, plus a few ones that are less common on hardware synthesizers.

Menu: [**mod**] → turn [**left**] until the desired modulation slot is shown on the menu display. Then push [**P2:DEST**] → turn [**right**]

Supported **Modulation Destinations** are: {OSC1 Freq, OSC2 Freq, OSC1 Shape, OSC2 Shape, OSC1 & OSC2 Freq, OSC1/OSC2 Mix, SUB1 Level, OSC1 FM, FILTER Freq, FILTER Env, FILTER FM, FLT Attack Time, FLT Decay Time, FLT Sustain Lvl, FLT Release Time, AMP Level, LFO1 Freq, LFO2 Freq, LFO3 Freq, LFO1 Level, LFO2 Level, LFO3 Level, Mod Env Level, FX1 Mix, FX2 Mix, Drive}

Modulation Level

The **Modulation Level** of each modulation slot is defined in the range [-63..+63]. Modulations are normalized so that it is always possible to span the full range of the destination parameter. The base value of the destination parameter also needs to be tuned to allow for the full swing of the modulation. The levels for the first 2 slots are accessed by dedicated knobs on the panel, while the other modulator levels are reached by the menu.

Panel: [**mod1 level**] or [**mod2 level**]

Menu: [**mod**] → turn [**left**] until the desired modulation slot is shown on the menu display. Then push [**P3:LEVL**] → turn [**right**] {-63..+63}

The following Sound design tips provide practical examples of using modulations.

Sound design tip: *creating a tremolo effect using the modulation matrix. Tremolo is an effect where the volume is modulated rapidly. Let's go through the steps for setting up tremolo in Polyvera:*

- *Begin by configuring the tremolo LFO (say, LFO1). A triangular **waveform** and a **frequency** of a few Hz (value 75) are a good starting point. **Key Trigger** should be disabled. Since we want to use a single LFO and share it across all the voices, enable **Lfo1Common** in the LFO page in the **voice** menu.*
- *Adjust the base value of **Amp Level** low enough, so that it will still be within its useful range even when modulated. Setting a parameter half-way (64) is often a good starting point.*
- *Define a first modulation slot, by selecting an LFO as **Mod1 Source**, the Amp Level as **Mod1 Destination** and adjust **Mod1 Level** to taste (+10 is a good starting point).*

Sound design tip: when modulating pitch (**osc frequency**) using an LFO, some modulation levels are particularly important:

- **Mod Level=23** gives a pitch modulation of +/- 6 semitones, hence one octave in total.
- **Mod Level=43** gives a pitch modulation of +/- 12 semitones, hence 2 octaves in total.
- **Mod Level=63** gives a pitch modulation of +/- 18 semitones, hence 3 octaves in total.

Sound design tip: advanced tremolo effect. Polyvera allows to modulate modulation sources parameters such as the LFOs level and frequency. For example, the intensity and frequency of tremolo in the previous Sound design tip can be controlled by another modulator, such as a Mod Wheel. To do so:

- Follow the steps in the previous Sound design tip, until you have a good basic tremolo
- To modulate the intensity of tremolo, reduce **LFO1 level** until you achieve the lowest desired tremolo intensity. Zeroing **LFO1 level** completely removes tremolo. Note that the LFO led blinking intensity reflects the current LFO1 level.
- Set a second modulation slot, using ModWheel+ as **Mod2 Source** and LFO1 Level as **Mod2 Destination**. Now play some notes, move the Mod Wheel to its maximum value, and increase **Mod2 Level** until the maximum desired level of tremolo is achieved.

For a more interesting sound, it can be useful to modulate the tremolo frequency, together with its intensity. This is done by using a third modulation slot with Mod Wheel as **Mod3 Source** and **LFO1 Freq** as **Mod3 Destination**. By setting a negative **Mod3 Level**, the frequency of tremolo decreases while its intensity increases, which can be a pleasant effect.

Fast Panel-Based Modulation Setting

There is a convenient way to set **Modulation Destination** and **Modulation Level** using the panel, by following these steps:

1. Select the modulation slot to be modified using the usual menu procedure **[mod]**→ turn **[left]**
2. Push **[P2:DEST]** or **[P3:LEVL]** + turn the knob of the parameter to be modulated. The **Modulation Destination** is automatically set to the parameter corresponding to the turned knob, and the **Modulation Level** corresponds to the knob position. A 12-

o' clock knob corresponds to no modulation, turning left gives a negative Modulation Level, turning right gives a positive Modulation Level.

Effects

Polyvera offers two configurable in-series effects. Up to 5 effects parameters are provided per Effect Type, which can be freely adjusted and stored with sound presets. Delay effects can also be synchronized to the master tempo.

Effect Type

Panel: Push **[fx/attack]** until "fx1" or "fx2" is selected → Turn **[fx/attack]**

Menu: **[fx1]** or **[fx2]** → **[P1:TYPE]**

The following **Effect1 Types** are currently offered:

Effect1 Type	Par1	Par2	Par3	Par4	Par5	Comment
ChorSin:Bright	Rate	Depth				Bright chorus inspired by a famous 70s pedal
ChorDb1:Junoish	Rate					Rich chorus inspired by a famous 80s synth
ChorDb1:Dimension	Rate	Depth				Atypical chorus with a nice stereo width and mild modulation
DigiDly:Long	Time	Repeat	LP flt	HP flt		Somewhat darker digital delay with up to 1.3s delay
DigiDly:PingPong	Time	Repeat	LP flt	HP flt	Time Ratio	Stereo ping pong delay, time-ratio regulates the delay ratio on the 2 channels
DigiDly:Reverse	Time	Repeat	LP flt	HP flt		Reverse delay
AnaDly:Alias	Time	Repeat	Mod Freq	Mod Depth		Lo-fi analog delay with obvious alias artifacts and long maximum

						delay (1.25s)
Phaser:MXR90	Rate	Depth	Res			Classic phaser pedal
Phaser:InvPh	Rate	Depth	Res			Phaser variation with negative phase feedback
Phaser:6Stages	Rate	Depth	Res			Rich phaser
Bitcrusher:Decimate	Freq	Bits	Mod Freq	Mod Depth		Decimator with frequency modulation
Distortion:Diode	Gain	LP flt	HP flt			Simple diode-based saturator

The following **Effect2 Types** are currently offered:

Effect2 Type	Par1	Par2	Par3	Par4	Par5	Comment
Rev:Hall	Length	Damp	Pre Delay	ModLvl	Input Level	Classic Hall reverb with an 80s flavor
Rev:Plate	Length	Damp	Pre Delay	ModLvl	Input Level	Classic Plate reverb with an 80s flavor
Rev:Cosmos	Length	Damp	Pre Delay	ModLvl	Input Level	Long, rich, modulated reverb, perfect for drones, pads and ambient
Rev:Grains	Length	Damp	Pre Delay	ModLvl	Input Level	Lo-fi delay with audible reflections and unrealistic modulation, which actually sounds pretty cool

Effect Mix

Panel: **[fx1 mix]** or **[fx2 mix]**

These parameters control the balance between dry and wet signal.

Effect Parameters

Panel: Push **[fx/attack]** until “fx1” or “fx2” is selected → Turn **[fx par1]** or **[fx par2]**

Menu: **[fx1]** or **[fx2]** → **[P3:PARA]** → **[Par1], [Par2], [Par3], [Par4], [Par5], [Par6]**

Every effect has a specific set of configurable parameters, which are listed in the Effect Type section above. The first two parameters of each effect are accessible from the panel, the remaining ones from the menu.

Effect Synchronization

Menu: **[fx1]** → **[P3:PARA]** → **[Sync]** {Off,On}

This parameter is only applicable to delay effects, and it synchronizes the delay time to the master tempo. The actual delay time is chosen with the **Effect1 Par1** parameter and it is expressed as a fraction of a bar (i.e., 4 beats). If the desired delay time is too long for the selected Effect Type, a “*” is shown next to the **Effect1 Par1** value on the display.

Arpeggiator

Panel: **[arp on]**

Polyvera includes a classic arpeggiator, which is toggled by the **[arp on]** button on the panel. Note that the arpeggiator and sequencer may not be engaged simultaneously.

When **hold** is active, the arpeggiator remembers the latest played chord. The old chord may be replaced by pressing a new chord after all keys from the previous chord have been released.

Arp Pattern

Menu: **[arp/seq]** → **[ARP]** → **Pattern** {Up, Down, UpDown, Random, Assign}

The **Arp Pattern** parameter determines the order in which the input notes are replayed by the arpeggiator. Assign means that the notes are replayed in the same order as they are input.

Arp Step Length

Menu: **[arp/seq]** → **[ARP]** → **StepLen** {1/1, 1/2, 1/4, 1/8, 1/16, 1/32}

The **Arp Step Length** parameter determines the duration of the steps, referred to the master tempo bar (i.e., 4 beats).

Arp Gate Length

Menu: **[arp/seq]** → **[ARP]** → **GateLen** {1 step, ½ step, ¼ step}

The **Arp Gate Length** parameter determines the duration of the played notes in relation to the step length.

Arp Range

Menu: [arp/seq] → [ARP] → **Range** {1 octaves, 2 octaves, 3 octaves}

The **Arp Range** parameter determines the number of octaves that the arpeggiator pattern spans over.

Sequencer

Panel: [seq on]

Polyvera includes a 64-step polyphonic sequencer, which is toggled by the [seq on] button on the panel. Note that the arpeggiator and sequencer may not be engaged simultaneously.

The sequencer can re-play chords, but it only processes a single input note at the time, which is the latest input note. When **hold** is active, the sequencer remembers the latest played note.

Before the sequencer can be used, a sequence needs to be recorded. Sequences are stored in the sound presets and a few example sequences are available in the factory presets. Check the Sequence Recording section for details on how to record a new sequence.

Blinking LEDs on the menu buttons indicate the index of the step currently being played. The 8 buttons on the lower row indicate step index modulo 8, while the upper row menu buttons indicate step index ranges [1-8], [9-16], [17-24] and [25-32].

In addition to notes, every step may also play an automation event, which controls a sound parameter. Different steps can carry different automation events.

Seq Step Length

Menu: [arp/seq] → [SEQ] → **StepLen** {1/1, 1/2, 1/4, 1/8, 1/16, 1/32}

The **Seq Step Length** parameter determines the duration of the steps, referred to the master tempo bar (i.e., 4 beats).

Seq Restart

Menu: [arp/seq] → [SEQ] → **Restart** {Continue, RestartSeq}

The **Seq Restart** parameter determines if the sequence should be continued from its latest step, or restarted from its first step, whenever a new input note is triggered.

Seq Number Of Steps

Menu: [arp/seq] → [SEQ] → *NrOfSteps* {1..64}

The **Seq Number of Steps** parameter determines the number of active steps in the sequence playback. Whenever the sequence playback reaches **Seq Number of Steps**, the sequence is replayed from step 1.

Seq Play Mode

Menu: [arp/seq] → [SEQ] → *PlayMode* {Manual, Gated}

The **Seq Play Mode** parameter controls the sequence play trigger. When Manual is selected, the sequence is played while **seq on** is active. If Gated is active, the sequence is played while **seq on** is active and a key is pressed. The sequence is transposed so that its first step note matches the trigger note.

Sequence Recording

Before the Sequencer can be used, a sequence needs to be recorded. Sequences include up to 64 steps, which are played back repeatedly by the sequencer.

A sequence includes two types of events: notes and automation. Every step includes up to 6 notes and at most 1 automation event. Notes and events can be recorded and edited step by step. Events may also be recorded live, during sequence playback.

Step Recorder

Menu: [seq rec] (note that [seq on] must be Off)

When the Step recorder is active, the [seq rec] button blinks and the Step Edit menu is shown on the main display. The current step index is indicated on the main display and by the blinking menu buttons. To select a specific step, turn the [left] encoder.

To adjust the length of the notes in the step, turn the [right] encoder. If note length Mute is chosen, the step will not playback its notes. The note length is relative to the step length. Notes that are longer than one step last multiple steps. The note length parameter applies to all notes in the step.

Step notes are provided by playing up to 6 notes in a chord, via the MIDI input or the onboard mini-keyboard. After all keys are released, the step recorder automatically jumps to the next step. The step notes are shown on the display.

Automation is recorded by moving a sound parameter knob on the panel while the corresponding step edit page is open. The step automation event is shown on the display. Note that only one parameter can be automated on a single step, however

different steps can automate different parameters. If multiple knobs are moved, only the latest parameter change is stored in the step.

The following parameters can be automated: **Mod-Wheel, MPE Slide, Osc1 Shape, Osc2 Shape, Osc1 FM, Sub-Osc1 Level, Osc1/Osc2 Mix, Filter Frequency, Filter Resonance, Filter Drive, Filter FM, Filter Key Tracking, Mod1 Level, Mod2 Level, Filter Attack, Filter Decay, Filter Sustain, Filter Release, Filter Env Level, Amp Attack, Amp Decay, Amp Sustain, Amp Release, Amp Level, Mod-Env Attack, Mod-Env Decay/Release, Mod-Env Sustain, Effect1 Mix, Effect2 Mix.**

Step notes are deleted by pushing **[P1/DELNOTE]**. All notes in the sequence can be deleted at once by pushing **[shift] + [P1/DelAINOT]**.

Step events are deleted by pushing **[P3/DELAUTO]**. All automation in the sequence can be deleted at once by pushing **[shift] + [P3/DelAIAU]**.

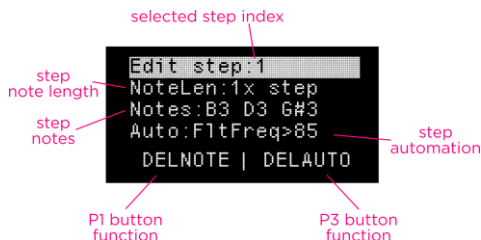

Live Recorder

Menu: push **[seq rec]** as long as parameters should be live-recorded. Note that **[seq on]** must be On and a sequence must be playing.

It is possible to record automation events while a sequence is playing. During each step, Polyvera records the latest input automation and overrides any automation that might have previously been recorded on that same step.

Audio Recorder

Panel: **[shift] + [osc2/audio rec]**

Polyvera includes a stereo audio recorder, primarily intended for sampling external audio input. The audio recorder can include root key information in the file header and can automatically load the sample to the sampler.

The audio to be recorded must be input to the **Audio In** connectors. In case of mono audio, the left input must be used. The level of the input signal is shown on the voice

LEDs above the main display, which act as input level meters while audio recording mode is enabled. Overloading the audio input is not a good idea! Make sure that audio recordings don't reach the last LED, or they will result in digital clipping.

When in audio recording mode, the osc display shows the recorded time, the sample name and the selected trigger method. The **[B1]** and **[B2]** buttons are used for starting, stopping and confirming recordings.



When in audio recording mode, the main display provides control over recording parameters.

When the audio recorder is enabled, the sound engine is halted. To exit the audio recording mode, push **[osc2/audio rec]**.

Recorded audio files are stored to the User folder on the SD memory card.

Start/stop Audio Recording

To start audio recording, Polyvera must first be set in audio recording mode by **[shift] + [osc2/audio rec]**.

To start the actual recording, push **[B1/START]**. If the **recording trigger** is set to manual, recording will start immediately and the time counter will start rolling. If the **recording trigger** is set to auto, recording will start automatically as soon as audio is detected on the input.

To stop recording, push **[B2/STOP]**. The display will now ask if the recording should be confirmed or discarded. If **[B1/DISCARD]** is pushed, Polyvera gets ready to record a new sample. If **[B2/CONFIRM]** is pushed, the audio recording is stored to the SD card. If the **sample autoloading** option is enabled, the recording is also automatically loaded to the sampler and the audio recording mode is automatically quit.

Audio Recorder Parameters

When the audio recording mode is enabled, the main display provides control over relevant parameters, which should be adjusted before starting the actual recording.

Audio Recording Filename

Menu: **[P1/SETT]** → **[Filename]**

The display shows the chosen filename for the recording. If the filename is not unique in the folder, Polyvera automatically generates a variation by appending a progressive index. The actual name of the upcoming recording is shown in the Osc menu.

To modify the filename, push **[P3/RENA]** and follow the same procedure used to rename sound presets.

Audio Recording Level

Menu: **[P1/SETT]** → **Level** {-40..0}

Gain of the Audio input in dB. The actual level is shown on the voice LEDs. It is strongly advised to avoid overdriving the Audio input, as it will result in digital clipping. The rightmost voice LED indicates digital clipping.

Audio Recording Trigger

Menu: **[P1/SETT]** → **Trigger** {Manual, Auto}

When **Audio recording trigger** is set to *Manual*, recording starts as soon as **[START]** is pushed.

When **Audio recording trigger** is set to *Auto*, recording is only armed after **[START]** is pushed. The actual recording starts when the signal level exceeds a threshold. This is useful for automatically avoiding recording unnecessary silence before the sound of interest.

Audio Recording Root Key

Menu: **[P1/SETT]** → **RootKey** {A0..C8}

Polyvera includes **Sample Root Key** information in the file header. It is recommended to set the **Audio Recording Root Key** correctly, in order to automatically load the sample parameters correctly later in the Sampler Osc.

Audio Recording Sample Autoload

Menu: **[P1/SETT]** → **AutoLoad** {Off, On}

If **Audio Recording Sample Autoload** is enabled, the Audio Recorder is automatically closed after storing the file and the Sampler Osc automatically loads the recorded file. This option is recommended for faster workflow.

Audio Recording Pre-Trigger

Menu: [P1/SETT] → *Pre-trig {0..49.7ms}*

Audio Recording Pre-Trigger allows to save a short portion of the audio file that precedes the moment when audio recording is started. **Audio Recording Pre-Trigger** is useful to avoid accidentally cutting the attack of a sound.

Audio Recording Format

Menu: [P1/SETT] → *Format {48k/24/St, 24k/24/Mo}*

Polyvera records at 48kHz/24bit, in mono or stereo. Please consider that the Sampler Oscillator plays the sample on a single voice, hence there is no strong motivation for recording in stereo.

User Samples

How to Import User Samples

Polyvera can use .wav samples in the following formats:

Sampling frequency	Resolution	Channels
44.1kHz, 48kHz (preferred)	16bit fixed, 24bit fixed (preferred), 32bit fixed, 32bit floating point	Mono (preferred), Stereo

New samples can be added in two ways:

- By sampling the sound in Polyvera
- By copying the .wav file to the SD memory card

The sampling method is covered in the Audio Recorder section of this manual and will not be discussed further here. The method of copying .wav files requires the following steps:

1. Turn Polyvera off and extract the SD memory card
2. Open the SD memory card on a computer and copy the .wav samples to the User folder. It is possible to create up to 16 subfolders within the User folder, with up to

128 samples each. Read the readme.txt file on the SD card for important naming conventions.

3. Safely eject the SD memory card from the PC and insert it back into Polyvera while it is turned off

4. The new samples will now be available in the User Bank. Additional user subfolders will become visible after the User Bank, when browsing sample banks.

Sample information can be encoded in the .wav file header and be automatically loaded by Polyvera. This includes the sample root key, the type of loop and the loop start/end indexes. The Appendix provides useful information for creating loop points and root key data on a PC and saving time when loading samples.

At most, 128 samples can be used within any folder.

Samples Pre-processing

Polyvera's vintage models require heavy processing, which is not possible at runtime. Hence, Polyvera creates pre-processed versions of each sample in proprietary format, whenever a sample is loaded for the first time. Such sample pre-processing is done only once per each sample. The factory sample library has already been preprocessed.

Polyvera pre-processes a new sample as soon as it is loaded into the Sampler Oscillator for the first time. This operation takes approximately a second for every second of audio content (the actual processing time depends also on the file format).

If many samples are imported at once, it may be preferable to let Polyvera pre-process many files at once, automatically, for example while the instrument is not being used or during a coffee/tea break. This can be done from the menu, as explained in the rest of this section.

Sample Stereo to Mono Pre-processing

Menu: **[sample]** → **[P3:PREP]** → **Stereo** {L+R->mono,L->mono,R->mono}

First of all, one needs to decide how to process stereo samples. Polyvera maps each sample to a single voice, hence the sample needs to be made monophonic. The parameter above lets the user choose whether the L and R channels on the sample should be mixed, or whether only the L or R channel should be used. As general rule, I recommend to avoid mixing L and R channels to prevent possible phasing issues.

Sample Preprocess

Menu: [sample] → [P3:PREP] → *PrepSample* {Current, FolderNew, FolderAll, AllNew, All}

- *Current sample*: pushing [right] forces pre-processing of the sample that is currently selected in the Sampler Oscillator. Since the sample is already loaded by the Sampler, it must have already been processed before, however in some cases it may be good to force pre-processing, for example for changing the stereo to mono pre-processing setting.
- *User Bank (new samples)*: pushing [right] forces pre-processing of all unprocessed User samples, including User subfolders.
- *User Bank (all samples)*: pushing [right] forces pre-processing all unprocessed User samples, including User subfolders. This is useful for cleaning up the SD card, but may take a long time if many samples are available.

User Wavetables

How to Import User Wavetables

Polyvera can read .wav wavetables in the following formats:

Sampling frequency	Resolution	Channels	Frame length	Number of frames
Any	8bit, 16bit fixed, 24bit fixed (preferred), 32bit fixed, 32bit floating point	Mono	128, 2048	Recommended: 1-64. Up to 256 is supported.

Copying .wav wavetables requires the following steps:

1. Turn Polyvera off and extract the SD memory card
2. Open the SD memory card on a PC and copy the .wav wavetables to the Polyvera_data/User/Wavetables128 or Polyvera_data/User/Wavetables2048 folder. You may also create up to 8 subfolders within Wavetables2048 and up to 4 subfolders within Wavetables128.
3. Safely eject the SD memory card from the PC and insert it back into Polyvera while it is turned off

4. The new samples will now be available in the *User128* and *User2048* Banks, or in Banks with the name of their subfolder. Note that renaming subfolders or moving wavetables will break presets that used those wavetables.

Important: the `Polyvera_data/User/Wavetables128` folder should only be used for original vintage wavetables that are 128 samples long and 8bit in resolution. Wavetables with 2048 samples should be copied to `Polyvera_data/User/Wavetables2048`.

At most, 128 wavetables can be used within any folder.

MIDI Settings

MIDI settings are stored as soon as they are changed, and they are remembered at next startup. MIDI settings are not stored with sound presets. Please note that firmware updates may revert MIDI settings to their default values.

Polyvera is an MPE (MIDI Polyphonic Expression)-compatible synthesizer, which allows unprecedented expressiveness when an MPE-capable controller is used. MPE is a subset of the MIDI spec that allows for highly expressive note-by-note data to be sent and received over MIDI. The essential idea is simple: MPE allows a synthesizer to be controlled by up to 16 MIDI Channels at once, one for global control (MPE Zone) and the others rotating to play different voices as required (MPE Member Channels). This allows for each voice to respond not only to its own aftertouch data, but also pitch bend, and slide (CC74). In Polyvera's case, the global control MIDI channel is always channel 1

MPE controllers differ largely from each other, and some configuration steps may be required both on the controller side and on Polyvera. Things to watch out for are that the controller uses a single MPE Zone/Master channel on MIDI channel 1, that at least 6 MPE Member Channels are configured, that the Slide controller is mapped to CC74 and that MPE Pitchbend in semitones matches the value on Polyvera's **MPE Pitchbend Range** parameter (the MPE standard recommends a value of 48 semitones).

If you are not using an MPE controller, it is recommended to set **MIDI Mode** to *Classic*.

Basic MIDI Settings

MIDI Mode

Menu: **[midi]** → **[P2:RX]** → **Mode** {*Classic, MPE*}

MIDI Mode determines the MIDI protocol to be used. *Classic* is suitable when a conventional MIDI controller is used. *MPE* should be selected if an MPE controller is used. Please consider that selecting the incorrect **MIDI Mode** prevents normal operation.

MIDI Channel

Menu: [midi] → [P1:COMM] → *Channel* {1..16}

MIDI Channel determines the MIDI channel on which classic MIDI events are monitored and transmitted.

If *MPE MIDI Mode* is selected, the following channels are monitored:

- Master channel (MPE Zone): MIDI channel 1
- Member channels: 2-16

MIDI Interface

Menu: [midi] → [P1:COMM] → *Interface* {Disabled, DIN 5p, USB}

MIDI Interface determines the interface on which MIDI is received and transmitted. Note that only one interface at a time is used.

MIDI Controllers and Synchronization

MIDI Rx Type

Menu: [midi] → [P2:RX] → *RxType* {Only Notes, Notes+Modulators, All MIDI}

MIDI Rx Type determines which input MIDI events are read and which ones are filtered away:

- *Only Notes*: any incoming MIDI events other than NoteOn/NoteOff are ignored.
- *Notes+Modulators*: any incoming MIDI events other than NoteOn/NoteOff and Control Changes mapped to the Modulator Sources are ignored.
- *All MIDI*: all incoming MIDI events that are mapped to a Polyvera parameter or function are processed.

The detailed mapping between MIDI messages and Polyvera's parameters and functions is provided in the MIDI Specification section.

MIDI MPE Slide Polarity

Menu: [midi] → [P2:RX] → *MpeSlidePol* {Unipolar, Bipolar}

MIDI MPE Slide Polarity determines whether the MPE Slide should be used as a bipolar Modulation Source which rests on MIDI value **64**, or as a unipolar Modulation Source which rests on MIDI value *0*.

The MIDI mapping for **MPE Slide Polarity** is provided in the MIDI Specification section.

MIDI Mod-Wheel Polarity

Menu: [midi] → [P2:RX] → *ModWheelPol* {Unipolar, Bipolar}

MIDI Mod-Wheel Polarity determines whether the Mod-Wheel should be used as a bipolar Modulation Source which rests on MIDI value **64**, or as a unipolar Modulation Source which rests on MIDI value *0*.

The MIDI mapping for **MIDI Mod-Wheel Polarity** is provided in the MIDI Specification section.

MIDI Mod1 Polarity

Menu: [midi] → [P2:RX] → *MidiMod1Pol* {Unipolar, Bipolar}

MIDI Mod1 Polarity determines whether MIDI Mod1 should be used as a bipolar Modulation Source which rests on MIDI value **64**, or as a unipolar Modulation Source which rests on MIDI value *0*.

The MIDI mapping for **MIDI Mod1 Polarity** is provided in the MIDI Specification section.

MIDI Mod2 Polarity

Menu: [midi] → [P2:RX] → *MidiMod2Pol* {Unipolar, Bipolar}

MIDI Mod2 Polarity determines whether MIDI Mod2 should be used as a bipolar Modulation Source which rests on MIDI value **64**, or as a unipolar Modulation Source which rests on MIDI value *0*.

The MIDI mapping for **MIDI Mod2 Polarity** is provided in the MIDI Specification section.

MIDI Mod3 Polarity

Menu: [midi] → [P2:RX] → *MidiMod3Pol* {Unipolar, Bipolar}

MIDI Mod3 Polarity determines whether MIDI Mod3 should be used as a bipolar Modulation Source which rests on MIDI value **64**, or as a unipolar Modulation Source which rests on MIDI value *0*.

The MIDI mapping for **MIDI Mod3 Polarity** is provided in the MIDI Specification section.

MIDI Mod4 Polarity

Menu: [midi] → [P2:RX] → *MidiMod4Pol* {Unipolar, Bipolar}

MIDI Mod4 Polarity determines whether MIDI Mod4 should be used as a bipolar Modulation Source which rests on MIDI value **64**, or as a unipolar Modulation Source which rests on MIDI value *0*.

The MIDI mapping for **MIDI Mod4 Polarity** is provided in the MIDI Specification section.

MIDI Tx Type

Menu: [midi] → [P3:TX] → *TxType* {None, All MIDI}

MIDI Tx Type controls whether any MIDI messages are sent over the MIDI interface.

MIDI Tx Sync

Menu: [midi] → [P3:TX] → *TxSync* {Off, On}

MIDI Tx Sync controls whether MIDI sync messages should be sent over the MIDI interface.

MIDI Tx Seq/Arp

Menu: [midi] → [P3:TX] → *TxSeq/Arp* {Off, On}

MIDI Tx Seq/Arp controls whether MIDI NoteOn/NoteOff messages corresponding to the notes played by the arpeggiator should be sent over the MIDI interface.

Classic MIDI Pitchbend Range

Menu: [system] → [P1:SETT] → *PBRRange* {1..48} semitones

The **Classic MIDI Pitchbend Range** parameter controls the number of semitones swept by the Pitchbend MIDI message on the selected MIDI channel.

MPE Pitchbend Range

Menu: [system] → [P1:SETT] → *PBRngMPE* {1..48} semitones

This parameter is only used when **MIDI Mode** *MPE* is selected.

The **MPE Pitchbend Range** parameter controls the number of semitones swept by the Pitchbend MIDI message on the MPE MIDI Member Channels. This parameter is important for MPE controllers that allow individual notes pitchbend. The value set on

Polyvera must match the corresponding value on the MPE MIDI controller. Please refer to your MPE MIDI controller for clarification of the correct setting.

System Settings

System Version

Menu: **[system]** → **[P1:SETT]** → **Versions**

The **System Version** parameter visualizes the current firmware and hardware.

Potentiometers Behavior

Menu: **[system]** → **[P1:SETT]** → **PotValue** {*Immediate, Smooth*}

The **Potentiometers Behavior** parameter controls the behavior of potentiometers on the panel.

- *Immediate*: as soon as potentiometer is moved, the associated parameter jumps immediately to the value corresponding to the knob position. This enables fast control of all parameters, but it can determine abrupt changes in the sound when a newly loaded preset is edited.
- *Smooth*: when a potentiometer is moved, the associated parameter does not change until the knob matches the current value of the parameter. This slows down sound editing when a new preset is loaded, but it prevents abrupt changes in the sound.

Read Wavetable Metadata

Menu: **[system]** → **[P1:SETT]** → **WavetMeta** {*Disabled, Read Wavet. Meta*}

When browsing wavetables, Polyvera looks for a Serum®-compatible metadata header in the .wav file. The **Read Wavetable Metadata** setting specifies whether Polyvera's local **Frame interpolation** parameter should be overridden whenever new wavetable metadata is read.

Read Sample Loop

Menu: **[system]** → **[P1:SETT]** → **SampleMeta** {*Disabled, Read Sample Loop*}

When browsing samples, Polyvera looks for loop metadata header in the .wav file. The **Read Sample Loop** setting specifies whether Polyvera's local **Loop Type** parameter should be overridden whenever new sample metadata is read.

Expression Pedal

See **Performance Control** → **External Pedals** for details on using the expression pedal.

Menu: **[system]** → **[P1:SETT]** → **PedalDest** {*Off, Amp, Filter*}

If you are not using a pedal, set **Pedal Destination** to *Off*. The latest setting is loaded at startup.

LEDs Brightness

Adjust the brightness of LEDs and panel.

Menu: **[system]** → **[P1:SETT]** → **LedBrightn** {*Off, Dim, Bright*}

Using the External Audio Input

The external stereo Audio In is mixed with Polyvera's own voices at the output of the VCAs and it is processed with the same stereo effects. It is primarily intended for applying Polyvera's own effects to external audio sources. It is recommended to disable the external Audio In when it is not used.

The same external Audio In is also used for the Audio Recorder, which is discussed in its own section.

External Audio Input Enable

Menu: **[system]** → **[P2:EXTIN]** → **Enable** {*Off, On*}

When **External Audio Input Enable** is *On*, line signals on the Audio In connectors are mixed with Polyvera's own voices. The stereo image of the stereo input follows the same stereo panning applied to Polyvera's own voice. For maximum stereo separation, set Play Mode to Binaural or UnisonWide.

It is recommended to disable the external Audio In when it is not used.

External Audio Input Gain

Menu: **[system]** → **[P2:EXTIN]** → **Gain** {-40..0} dB

External Audio Input Gain controls the gain on the external input. For best noise performance, increase the output volume of the device connected to the external Audio In, and reduce **External Audio Input Gain** accordingly.

Calibrating the Filters

Polyvera's analog technology is sensitive to environmental conditions such as temperature, humidity and mechanical stress. A calibration procedure is provided to improve the filters' frequency control over their full range.

Polyvera’s filters are calibrated when the product is tested in the lab, however a new calibration may be needed when environmental conditions change largely, or when a new firmware is installed.

Calibrate

Menu: **[system]** → **[P3:CALI]** → *Calib+reboot?*

After pushing **[right]**, the automatic calibration routine will execute for a couple of minutes, and the instrument will be automatically rebooted afterwards. It is important to let Polyvera be untouched while the calibration routine is executing.

Note that calibration cannot be interrupted and any unsaved sound data will be lost after the automatic reboot.

Revert Calibration

Menu: **[system]** → **[P3:CALI]** → *Revert?*

After pushing **[right]**, the default calibration parameters will be restored, and the instrument will be automatically rebooted afterwards. These parameters are not specific for your unit and will not provide accurate calibration. This function is primarily useful for troubleshooting, for example after a failed calibration.

Note that any unsaved sound data will be lost after the automatic reboot.

Appendix

MIDI Specification

Most of Polyvera’s parameters can be controlled via MIDI messages and most of the panel’s controls can transmit over MIDI. Please refer to the related sections of this manual to configure MIDI in/out behavior according to your needs. This section provides a list of the MIDI-mapped parameters and functions.

MIDI messages that control an On/Off parameter are mapped to 0-63=Off, 64-127=On.

MIDI messages that a parameter with a list of possible values (e.g., a wavetable index) are ignored when the data value exceeds the range of the associated parameter.

All parameters are either mapped to a Control Change (CC) or to a NRPN.

MIDI Message	Parameter
--------------	-----------

CC1	Mod-Wheel
CC5	Portamento time
CC3, NRPN1, NRPN2, NRPN3	Play Mode, UnisonDetune, PlayTransposeOctave, PlayTransposeSemitones
CC9, CC114, CC115, CC89	MidiMod1, MidiMod2, MidiMod3, MidiMod4
CC8, CC97, CC15, CC12, CC13, CC46, NRPN5, NRPN6	Osc1 Fine Freq, Osc1 Coarse Freq, Osc1 Type, Osc1 Wavetable Index, Osc1 Shape MSB, Osc1 Shape LSB, Osc1 Style, Osc1 Bank
CC17, CC18, CC20, CC21, CC22, CC55, NRPN7, NRPN114, NRPN8	Osc2 Fine Freq, Osc2 Coarse Freq, Osc2 Type, Osc2 Wavetable Index, Osc2 Shape MSB, Osc2 Shape LSB, Osc2 Wavetable Style, SamplerStyle, Osc2 Bank
CC65, CC66, CC67, NRPN9, CC68, CC69, CC70	OscMix, SubLevel, RingMod, Sync, OscFM, NoiseMix, NoiseColor
CC10, CC11, NRPN10, NRPN11, NRPN12, NRPN113	SampleBank, SampleIndex, SamplerLoopType, SamplerRootKey, SamplerPlayDirection, SamplerShapeCtrl
CC73, CC75, CC76, CC77, CC78	FilterEnvAmt, FilterEnvAttack, FilterEnvDecay, FilterEnvSustain, FilterEnvRelease

CC86, CC79, CC80, CC81, CC82	AmpLevel, AmpEnvAttack, AmpEnvDecay, AmpEnvSustain, AmpEnvRelease
CC83, CC84, CC85, NRPN16	ModEnvAttack, ModEnvDecayRelease, ModEnvSustain, ModEnvMode
CC87, CC88, CC29, CC61, CC96, NRPN18, CC90	FilterDrive, FilterFmAmt, FilterFreqMsb, FilterFreqLsb, FilterRes, FilterType, FilterTracking
CC91, CC92, CC93, CC94, NRPN19, NRPN20, CC95	Lfo1Waveform, Lfo1FreqAbs, Lfo1FreqSync, Lfo1Level, Lfo1Retrig, Lfo1Sync, Lfo1FadeInTime
CC59, CC60, CC25, CC62, NRPN21, NRPN22, CC63	Lfo2Waveform, Lfo2FreqAbs, Lfo2FreqSync, Lfo2Level, Lfo2Retrig, Lfo2Sync, Lfo2FadeInTime
CC26, CC102, CC103, CC104, NRPN23, NRPN24, CC105	Lfo3Waveform, Lfo3FreqAbs, Lfo3FreqSync, Lfo3Level, Lfo3Retrig, Lfo3Sync, Lfo3FadeInTime
CC106, NRPN26, CC107, CC108, NRPN27, NRPN28, NRPN29	Effect1 Mix, Effect1 Type, Effect1 Par1, Effect1 Par2, Effect1 Par3, Effect1 Par4, Effect1 Par5
CC109, NRPN31, CC110, CC111, NRPN32, NRPN33, NRPN34	Effect2 Mix, Effect2 Type, Effect2 Par1, Effect2 Par2, Effect2 Par3, Effect2 Par4, Effect2 Par5

CC112, CC113, CC36, CC37, CC116, CC117, CC118, CC119	Mod1 Level, Mod2 Level, Mod3 Level, Mod4 Level, Mod5 Level, Mod6 Level, Mod7 Level, Mod8 Level
NRPN36, NRPN37, NRPN38, NRPN39, NRPN40, NRPN41, NRPN42, NRPN43	Mod1 Source, Mod2 Source, Mod3 Source, Mod4 Source, Mod5 Source, Mod6 Source, Mod7 Source, Mod8 Source
NRPN44, NRPN45, NRPN46, NRPN47, NRPN48, NRPN49, NRPN50, NRPN51	Mod1 Dest, Mod2 Dest, Mod3 Dest, Mod4 Dest, Mod5 Dest, Mod6 Dest, Mod7 Dest, Mod8 Dest

Factory Library

Polyvera's factory library includes sound presets, wavetables and samples, which are stored on the included SD memory card. The factory library is expected to grow over time. Visit Suonobuono's website regularly to check for updates.

Sound presets: Up to 128 presets per bank can be stored. Factory presets may be freely overridden by user presets.

Wavetables: a few banks are provided, for easier selection:

- *Analog:* created by sampling iconic analog and modular synthesizers
- *Digital:* mostly created algorithmically or by sampling digital synthesizers.
- *Vintage:* waveforms reminiscent of the best classic 8bit wavetables
- *User_2048:* empty folder, intended for user-provided wavetables with 2048 samples per frame, according to the Serum® .wav format
- *User_128:* empty folder, intended for user-provided wavetables with 128 samples per frame and 8 bit resolution, according to the format of the original PPG Wave wavetables

Samples: several banks are provided, for easier browsing, Samples are ordered alphabetically within each folder: Acoustic, Analog, BasicWaves, Bass, Bells, Brass, Chords, Drums, Ethnic, Fairlight, Field, Fx, Keys, Leads, Mallets, Noises, Organs, Pads, Sequences, Strings, Voices.

It is recommended that user wavetables and user samples are only stored in the User folder, as discussed in the User Wavetables and User Samples sections.

Troubleshooting

Issue	Possible solutions
“SD init fail” is shown at startup	A valid SD card is not found in the slot.
“Warning! Calibrate Filters” is shown at startup	After a firmware update, filters may need to be calibrated. Please check the Calibration section of this manual.
I copied/moved a preset to a bank on the SD memory card, but it is not shown when browsing sound presets.	Polyvera reads the sound preset index and name from the preset .prst filename. If the predefined format is not strictly followed, the preset will not be found. If 2 presets with same index are placed in the same Bank folder, one of them will be ignored. Please check the readme.txt file on the SD memory card for details.
The SD memory card cannot be read correctly by Polyvera or by a computer	It is possible that the SD memory card got corrupted. Please format the SD memory card using Polyvera, refer to the manual. Once formatted, obtain the factory content from Suonobuono’s website and copy it to the SD memory card. Please note that all user presets and samples are lost when formatting the SD memory card. Make sure to backup those files regularly.
When increasing resonance, the filter pitch varies largely across voices	Filters may need to be calibrated. Please check the Calibration section of this manual.

An unpleasant clipping noise is present

Does the clipping LED light? If so, it is enough to lower **Amp Level**

SD Memory Card Formatting

It may happen that an SD Memory Card gets corrupted and needs to be formatted. Please note that formatting erases all data on the card, including user presets, user wavetables and user samples. Make sure to regularly backup your SD Memory Card to avoid loss of data.

Polyvera provides a robust SD Memory Card formatting function. To format the SD Memory Card, follow these steps:

1. Turn Polyvera off
2. Insert the SD Memory Card to be formatted in the SD Memory Card slot
3. Push **[shift] + [seq rec] + [save]** with one hand, while starting Polyvera with the other hand.
4. The display will warn you that formatting will start soon. If you regret the operation, turn Polyvera off immediately.
5. Wait until formatting is completed, it will take about one minute. A message will confirm the result.

Samples Creation Using a Computer

Samples can be conveniently edited on a computer and copied to Polyvera's SD memory card. A few aspects need to be considered:

- The format of the .wav file must be supported by Polyvera. Please check the User Samples section for a list of supported formats.
- The .wav file may include loop and root key information, which is automatically read by Polyvera's Sample Oscillator, whenever a new sample is selected. This section explains how to include loop and root key information in your samples, using a computer and free software.

When a new sample is loaded into the Sample Oscillator, the loop settings are read from the .wav file header using the "smp1" tag (<https://www.recordingblogs.com/wiki/sample-chunk-of-a-wave-file>). Unfortunately,

there exist multiple, incompatible, ways of including loop and root key data in .wav files, however the “smp1” tag is one of the common ones.

Polyvera’s factory content has been edited using Endless WAV, a freeware yet powerful loop editor which can be downloaded from:
<https://www.bjoernbojahr.de/endllesswav.html>

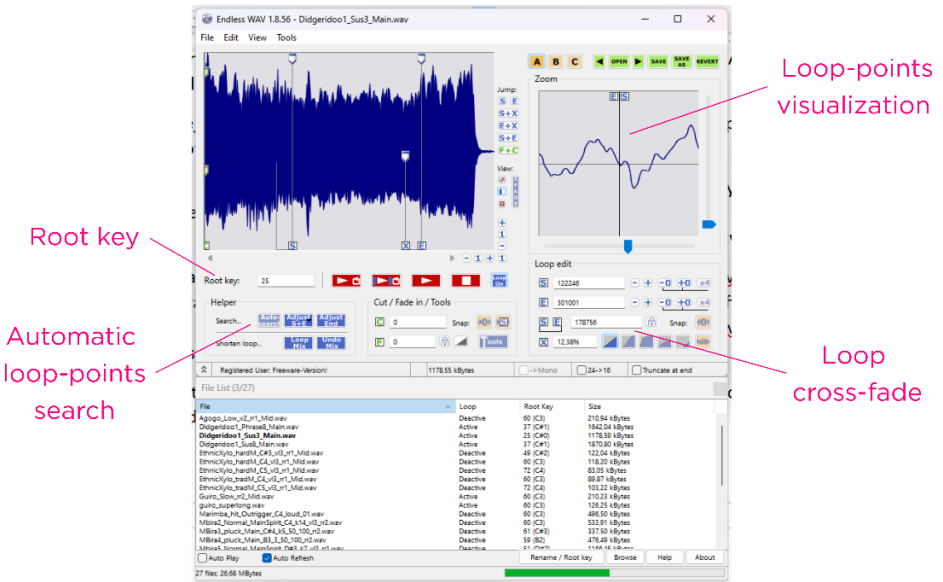

A few tips when using Endless WAV:

- The Root key field is convenient for storing the sample key in a format that Polyvera recognizes.
- The loop-points visualization window on the top-right helps to find the best loop points. The automatic loop search function can be a good starting point, even if it often needs to be adjusted manually. Difficult loops are often solved by adding a bit of cross-fading.

One limitation of Endless WAV is that it only supports the basic, Continuous loop. If you want to set an Alternating loop in the .wav header, my suggestion is to open the .wav file using Wavosaur, which is also freeware: <https://www.wavosaur.com/>. The Tools→Loop→Properties menu allows to select an Alternating loop. Make sure to set Type to infinity and that the Note index matches the correct sample root key.

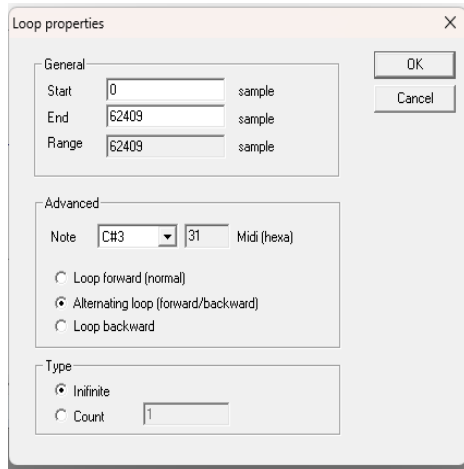

Wavetables Creation Using Xfer Records Serum® or Similar Software

Supported wavetable formats are listed in the User Wavetables section. Wavetables are .wav files that follow a specific structure. They do not sound pleasant when they are played in a wave player and they need special software to be created and edited. There are many good tutorials about wavetables creation, this section intends to only provide a couple of tips that are specific for Polyvera.

There are a number of freeware and commercial software for wavetable editing on the market. The majority of Polyvera's factory wavetables have been developed using Xfer records Serum®: <https://xferrecords.com/products/serum/> It is a commercial software which is well worth its cost, however the free demo version is enough for quick edits (it closes after 15 minutes of use).

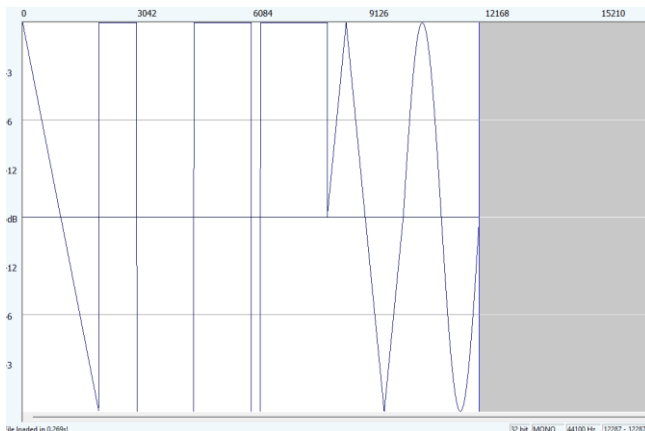

The above picture shows the .wav file behind the Analog Shapes wavetables in the factory library. Every frame consists of exactly 2048 samples, and in this case the whole wavetables includes 6 frames and $6 * 2048 = 12288$ samples. Note that wavetables are mono files and their sample-rate doesn't affect the way they sound. A wavetable may include up to 256 frames, however Polyvera only uses up to 64 frames.

A wavetable is easily created in Serum, by stacking waveforms next to each other. Once satisfied with the result, select Export All as 32bit (wav) from the Export menu. The wavetable file is now ready to be copied to Polyvera's SD memory card folder: Polyvera_data/User/Wavetables2048 folder.

Note that the wavetables in the above example are numbered 1-6. This implies that Polyvera will not interpolate across them, unless the **Wavetable Interpolation** is actively turned to *On*.

If you wish to let Polyvera interpolate across frames by default, set Morph-Crossfade from the Morph menu, as in the following figure, and then Export the file again. While there are still the same 6 frames, their number has been remapped to the 1-256 range. In practice, Serum has included a tag in the wavetable header telling Polyvera to enable **Wavetable Interpolation** whenever the wavetable is loaded.

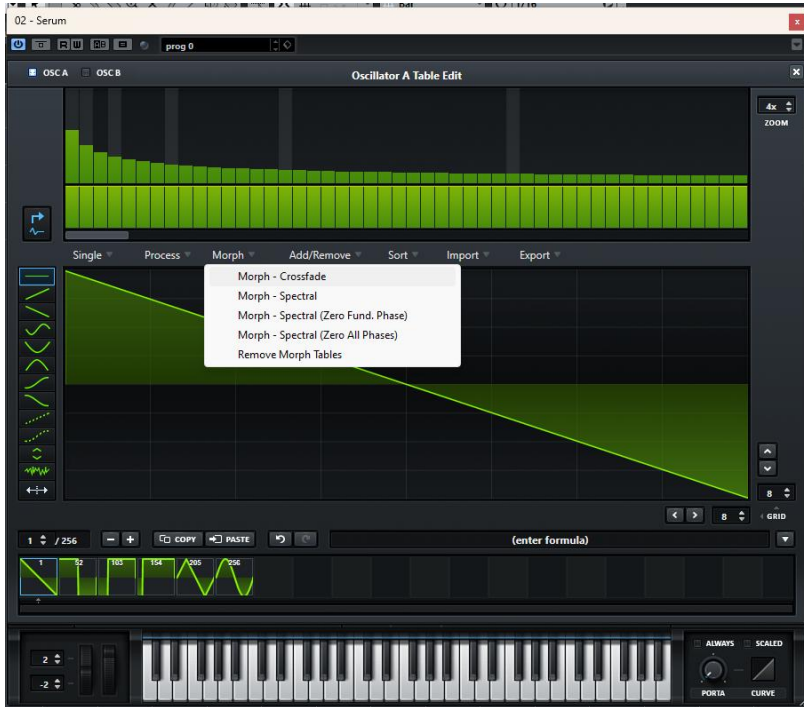

Legal Terms

FCC Information (U.S.A.)

1. **IMPORTANT NOTICE: DO NOT MODIFY THIS UNIT!** This product, when installed as indicated in the instructions contained in this Manual, meets FCC requirements. Modifications not expressly approved by Waldorf may void your authority, granted by the FCC, to use this product.
2. **IMPORTANT:** When connecting this product to accessories and/or another product use only high quality shielded cables. Cable/s supplied with this product **MUST** be used. Follow all installation instructions. Failure to follow instructions could void your FCC authorization to use this product in the USA.
3. **NOTE:** This product has been tested and found to comply with the requirements listed in FCC Regulations, Part 15 for Class „B“ digital devices. Compliance with these requirements provides a reasonable level of assurance that your use of this product in residential environment will not result in harmful interference with other electronic devices. This equipment generates/uses radio frequencies and, if not installed and used according to the instructions found in the user manual, may cause

interference harmful to the operation of other electronic devices. Compliance with FCC regulations does not guarantee that interference will not occur in all installations. If this product is found to be the source of interference, which can be determined by turning the unit „OFF“ and „ON“, please try to eliminate the problem by using one of the following measures: Relocate either this product or the device that is being affected by the interference. Utilize power outlets that are on branch (Circuit breaker or fuse) circuits or install AC line filter/s. In the case of radio or TV interference, relocate/reorient the antenna. If the antenna lead-in is 300 ohm ribbon lead, change the lead-in to co-axial type cable. If these corrective measures do not produce satisfactory results, please contact the local retailer authorized to distribute this type of product. The statements above apply ONLY to products distributed in the USA.

Europe

This device has been tested and found to comply with the limits of the European Council Directive on the approximation of the laws of the member states relating to Electromagnetic Compatibility according to 2014/30/EU. This device has been produced with lead free solder and fulfills the requirements of the ROHS directive 2011/65/EU.



WEEE

This symbol indicates that the electrical and electronic equipment should not be disposed of as general household waste at its end-of-life. Instead, the products should be handed over to the applicable collection points for the recycling of electrical and electronic equipment for proper treatment, recovery, and recycling in accordance with your national legislation and the Directive 2012/19/EU (WEEE – Directive on Waste Electrical and Electronic Equipment). For more information about collection points and recycling of these products, please contact your local municipal office, your household waste disposal service, or the shop where you purchased the product.



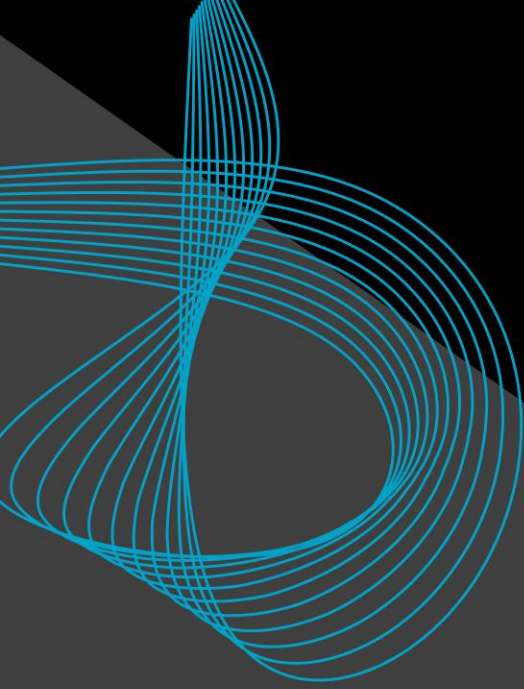

suonobuono
suonobuono.net
@suonobuono_instruments